

TZ
TAPE

P-touch

1300

USER'S GUIDE

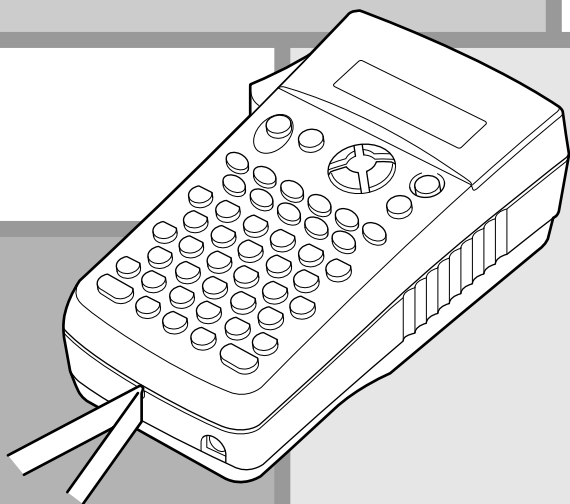

- Read this User's Guide before you start using your P-touch.
- Keep this User's Guide in a handy place for future reference.

At your side.
brother[®]

INTRODUCTION

Thank you for purchasing the P-touch 1300!

Your new P-touch will allow you to create labels and stamps for any application. Its versatility enables you to design custom labels by choosing from a variety of frame designs and from many character sizes and styles. In addition, the four tape widths (1/4" (6 mm), 3/8" (9 mm), 1/2" (12 mm) and 3/4" (18 mm)) and variety of tape colors allow you to print personalized labels, useful for color-coded filing.

You no longer have to worry about urgent tasks that require professional printing. The quality and performance of the P-touch 1300 makes it an extremely practical machine.

Although this machine is easy to use, we suggest that you read this User's Guide carefully before starting and keep it in a handy place for future reference.

Use only the adapter designed exclusively for this machine. See *GENERAL PRECAUTIONS* on page 4.

After using your P-touch, store it in the enclosed carrying case. This carrying case is designed to help protect the P-touch while enabling you to carry it anywhere you go.

FCC NOTICE

This equipment has been tested and found to comply with the limits for a Class B digital device, pursuant to Part 15 of the FCC Rules. These limits are designed to provide reasonable protection against harmful interference in a residential installation. This equipment generates, uses, and can radiate radio frequency energy and, if not installed and used in accordance with the instructions, may cause harmful interference to radio communications. However, there is no guarantee that interference will not occur in a particular installation. If this equipment does cause harmful interference to radio or television reception, which can be determined by turning the equipment off and on, the user is encouraged to try to correct the interference by one or more of the following measures:

- Reorient or relocate the receiving antenna.
- Increase the separation between the equipment and receiver.
- Connect the equipment to an outlet on a circuit different from that to which the receiver is connected.
- Consult the dealer or an experienced radio/TV technician for help.
- Changes or modifications not expressly approved by Brother Industries, Ltd. could void the user's authority to operate the equipment.

Patent numbers and patent publication numbers which are related to this product are as below:

USP4839742

USP4983058

USP5120147

USP4927278

USP5009530

USP4976558

USP5069557

CONTENTS

Getting Started

GENERAL DESCRIPTION	2
KEYBOARD & LCD DISPLAY	3
GENERAL PRECAUTIONS	4
BATTERIES	5
OPTIONAL AC ADAPTER	6
TAPE CASSETTE	7
ATTACHING LABELS	8
PRINT HEAD & ROLLERS	10
TAPE CUTTER.....	12
CARRYING CASE	13

For Your Information

POWER KEY	16
CODE & CAPS KEYS	17
CURSOR KEYS	19
SPACE KEY	21
RETURN KEY	22
BACKSPACE KEY	25
CLEAR FUNCTION	27
ACCENT FUNCTION	28
SYMBOL FUNCTION	30
LENGTH FUNCTION	32
SIZE & WIDTH FUNCTIONS	34
STYLE FUNCTION	37
UNDERLINE FUNCTION	39
FRAME FUNCTION	40
TAPE MARGIN FUNCTION	42
HORIZONTAL ALIGNMENT FUNCTION	46
MIRROR PRINTING FUNCTION	47
BARCODE FUNCTION	48
PRINT KEY & FEED FUNCTION	54
NUMBERING FUNCTION	55
REPEAT PRINTING FUNCTION	57
MEMORY FUNCTIONS	59
TROUBLESHOOTING	64
ERROR MESSAGE LIST	65
SPECIFICATIONS	69
ACCESSORIES	70

Getting started



GENERAL DESCRIPTION

TOP VIEW

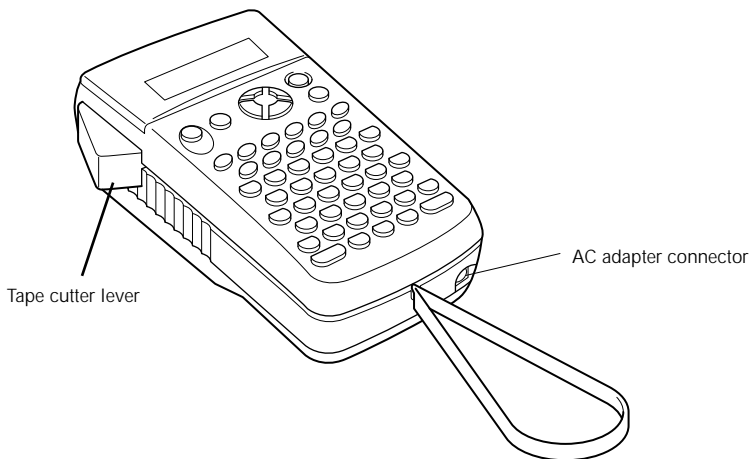

BOTTOM VIEW

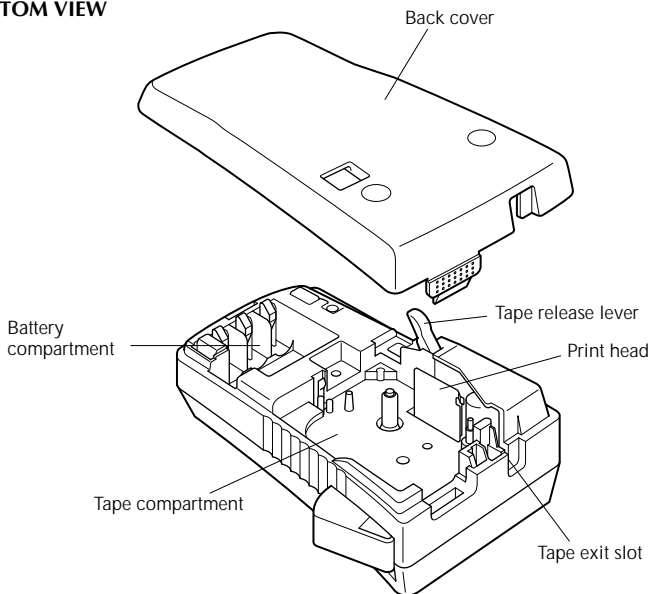

KEYBOARD & LCD DISPLAY

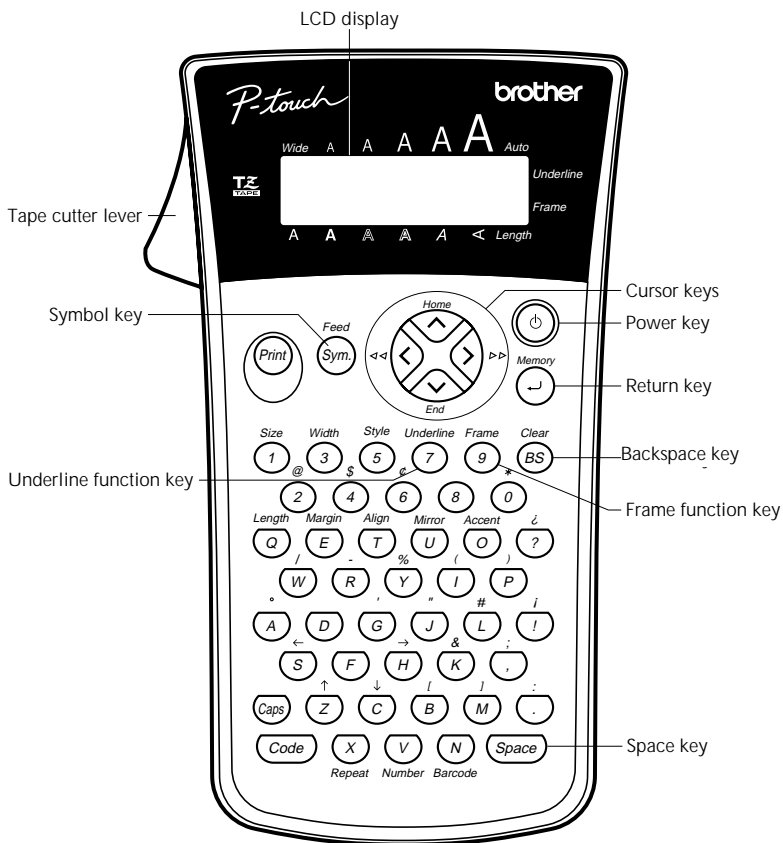

GENERAL PRECAUTIONS

- ⚠ WARNING:** Observe the following warnings in order to avoid damage to the P-touch or its accessories.
- Use only Brother TZ tapes with this machine. Do not use tapes that do not have the  mark.
 - Use only the AC adapter designed exclusively for this machine. Use of any other adapter will void the warranty.
 - Do not put any foreign objects into or anything on the machine.
 - Do not use the machine in dusty places, and keep it out of both direct sunlight and rain.
 - Do not expose the machine to high temperatures or high humidity. Never leave it on the dashboard or in the back of your car.
 - Do not leave any rubber or vinyl on the machine for an extended period of time. Doing so may cause staining.
 - Do not clean the machine with alcohol or other organic solvents. Only use a soft, dry cloth.
 - Do not touch the print head mechanism. If the head is touched, clean it immediately with a cotton swab to avoid permanent damage.
 - Do not pull on the tape being fed from the P-touch. This may damage the tape cassette.
 - When the machine is not being used for a long period of time and it is not necessary to keep the text files stored in the memory, disconnect the AC adapter, and remove the batteries to prevent them from leaking and damaging the machine.
- ⚠ CAUTION:** Observe the following cautions in order to prevent malfunction of the P-touch.
- When the AC adapter (AD-60) is connected, unplugging the adapter from the electrical outlet before unplugging it from the machine can delete all text files in the memory, even if batteries are installed.
 - Use six AA (AM3, LR6) alkaline batteries in this machine.

BATTERIES

This lightweight and portable machine can be used anywhere by installing six (6) **AA (AM3, LR6) alkaline batteries**. When changing the batteries, always replace all six at the same time.

To change the batteries:

- 1 Remove the back cover by pressing in on the rough area at the top end of the machine and pulling off the cover. Pulling off the back cover lifts up the tape release lever.
- 2 If batteries are already installed, remove them.
- 3 Insert six new batteries, making sure that they face the direction shown in the illustration on the bottom of the battery compartment. The positive ends of the three batteries in the bottom row point towards the bottom of the machine, while the positive ends of the top three batteries point in the opposite direction.
- 4 Attach the back cover by inserting the tab on the bottom end of the cover into the slot on the bottom end of the machine, then pushing down firmly on the top end of the cover until it snaps into place.

Be sure to insert the new batteries within five minutes of removing the old ones, otherwise the text shown in the LCD display and any text files stored in the memory will be lost (unless the machine is plugged into an electrical outlet with the AC adapter).

Remove the batteries and disconnect the AC adapter if you do not intend to use this machine for an extended period of time. When the power is disconnected, all text shown in the display and stored in the memory will be lost.

If alkaline batteries are not used, large fonts and barcodes cannot be printed.

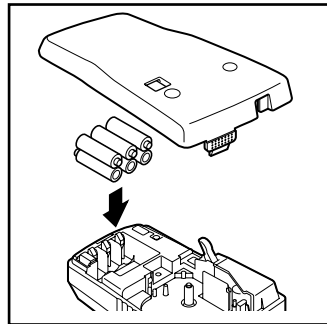
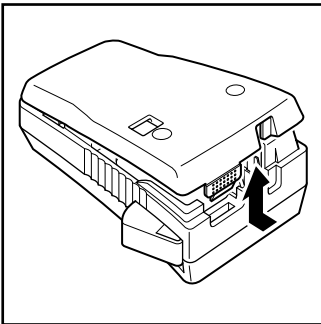

OPTIONAL AC ADAPTER

The AC adapter (AD-60) allows you to use this machine wherever there is an electrical outlet.

To connect the optional AC adapter:

- 1 Insert the plug on the adapter cord into the connector marked DC IN 9.5V on the bottom end of the machine.
- 2 Insert the plug on the adapter into the nearest standard electrical outlet.

☞ *Only use the AC adapter designed exclusively for this machine.*

Remove the batteries and disconnect the AC adapter if you do not intend to use this machine for an extended period of time. When the power is disconnected, all text shown in the LCD display and stored in the memory will be lost.

When the AC adapter is connected, unplugging the adapter from the electrical outlet before unplugging it from the machine can delete all text files in the memory, even if batteries are installed.

It is recommended that you use the AC adapter when printing large fonts and barcodes on 3/4" (18-mm)-wide tape since these operations can quickly drain the batteries.

TAPE CASSETTE

A single TZ tape cassette is supplied with this unit. However, since TZ tape cassettes are available for this machine in a wide variety of colors and sizes, it is possible to make distinctive color-coded and stylized labels. In addition, this machine has been designed to allow the tape cassettes to be changed quickly and easily.

To change the TZ tape cassette:



- 1 Remove the back cover by pressing in on the rough area at the top end of the machine and pulling off the cover. Pulling off the back cover lifts up the tape release lever.
- 2 If a tape cassette is already installed, remove it by pulling it straight out.
- 3 If the ink ribbon in the other tape cassette is loose, use your finger to wind the toothed wheel in the direction of the arrow on the cassette until there is no slack in the ribbon.

☞ *If you are using a new tape cassette provided with a stopper, be sure to remove the stopper before installing the cassette.*

Make sure that the end of the tape feeds under the cassette tape guides.

- 4 Insert the tape cassette firmly into the tape compartment, making sure that the entire back of the cassette touches the bottom of the compartment.

☞ *When inserting the tape cassette, make sure that the inner ribbon does not catch on the corner of the metal guide.*

- 5 Attach the back cover by inserting the tab on the bottom end of the cover into the slot on the bottom end of the machine, then pushing down firmly on the top end of the cover until it snaps into place.
- 6 Turn on the machine if it is off, and then feed the tape to remove any slack by holding down  and pressing  once.
- 7 Press in the tape cutter lever to cut off any excess tape.

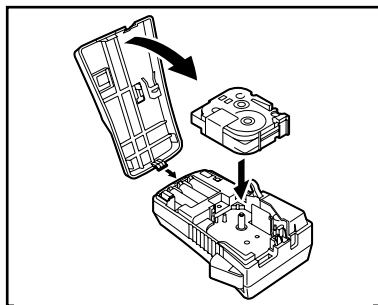
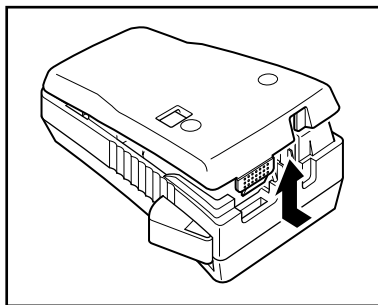

ATTACHING LABELS

Industrial (super-adhesive) tape

Compared to conventional laminated tape, industrial tape has a greater adhesive strength, providing better adhesion to difficult surfaces. Due to this improved adhesion, follow the precautions below when using this tape.

- Do not attach this tape to skin.
- Depending on the environmental conditions of the location and the quality of the material that this tape is attached to, the tape may become discolored or it may become impossible to remove it completely, possibly damaging the surface that it was affixed to.
- Before using this tape, test it by affixing a small piece to an unnoticeable area of the intended surface.
- If adhesive accumulated on the tape cutter makes it difficult to cut the tape, clean the tape cutter as explained on page 12.

LAMINATED TAPE

The enclosed tape separator enables you to easily remove the backing from labels printed on laminated tapes.

- 1 Hold the tape in your left hand, with the printed surface facing up, and hold the tape separator in your right hand.
- 2 Pass the tape halfway through the long narrow hole in the tape separator.
- 3 Turn the tape separator three-quarters of a turn towards you, and then pull the tape separator away from you as shown below.
- 4 Peel off the label backing.

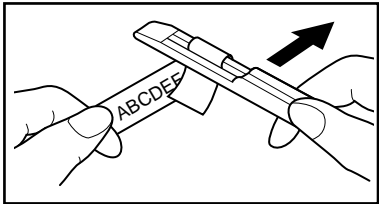
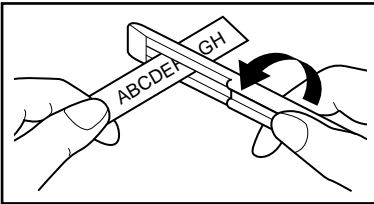

FABRIC TAPE

Fabric tape is used to attach a piece of fabric printed with your text onto garments using an iron. After printing the text onto fabric tape and cutting off the label using scissors, place the label on an ironed garment at the location where you wish to attach it in such a way that the printed text can be read correctly. Cover the label with another piece of cloth and use an iron set to a medium-high temperature (320 to 356 °F (160 to 180 °C)) to press down firmly for 10 to 15 seconds. For more details, refer to the instructions included with the fabric tape cassette.

☞ *The label will have a white background on colored cloth.*

STAMP TAPE

By making a stencil from TZ stamp stencil film and affixing it to a self-inking stamp film holder, you can easily create your own personalized stamps. To make a stamp using your P-touch 1300, install a MEDIUM stamp stencil film cassette (3/4" (18-mm)-wide stencil film with a 1/2" (12-mm)-wide print area) as described on page 7, and then enter the text as explained below.

- 1 Use the **length** function to set the tape length to 4.1" (10.5 cm).
- 2 Use the **horizontal alignment** function to select the **CENTER** setting.
- 3 Use the **tape margin** function to select the **FULL** setting.
- 4 Enter the text so that it fits within an area of 3/8" × 2.2" (9 × 55 mm).

To check the text and its length, remove the stamp stencil film cassette and insert a normal 1/2" (12-mm)-wide label tape cassette, and then print a trial label.

For more information refer to the instructions included with the Stamp Kit.

☞ *It is recommended that you use the AC adapter (AD-60) when printing stamps since these operations can quickly drain the batteries. Otherwise the stamps may not be printed correctly.*

PRINT HEAD & ROLLERS

Occasionally, specks of dust or dirt become attached to the machine's print head and rollers. This is particularly likely when you are using the unit outdoors or in a very dusty environment. If a section of the print head is covered with dust, a blank horizontal streak may appear through the label text. Therefore, as with a tape recorder, the machine's head may need to be cleaned from time to time.

To clean the print head and rollers:

- 1 Turn off the machine.
- 2 Remove the back cover, and then remove the tape cassette if one is installed. The print head and rollers are located in the tape compartment.
- 3 Print head: Use a dry cotton swab to gently wipe the print head with an up-and-down motion.
Rollers: Use a dry cotton swab to wipe each roller with an up-and-down motion while rotating them with your finger.
- 4 Install a tape cassette, attach the back cover, and then try printing again.
- 5 If dust still remains, repeat steps 2 through 4 using a cotton swab dipped in isopropyl (rubbing) alcohol.

If none of the above works, contact your service representative.

 *The print head can be cleaned more easily with the optional print head cleaning cassette TZ-CL4 (3/4" (18 mm)).*

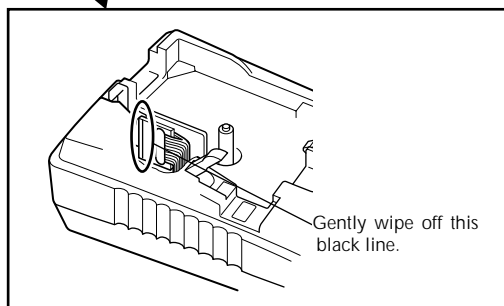
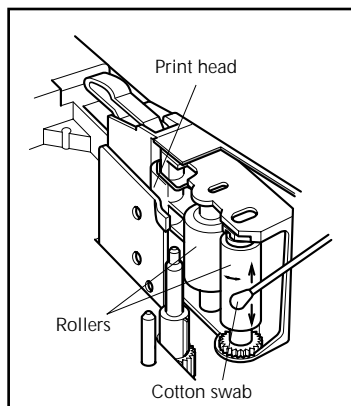
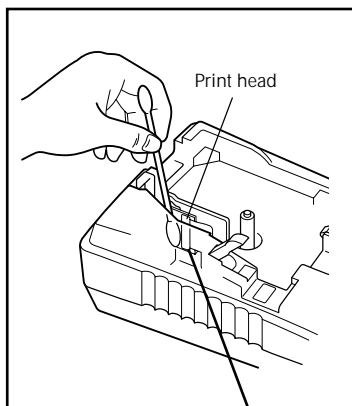

TAPE CUTTER

With use, the tape cutter may become covered with adhesive, making it difficult to cut the tape. If the tape cannot be cut correctly, clean the tape cutter blades as explained below.

 *To avoid injuries, be extremely careful not touch the cutter blades with bare hands.*

To clean the tape cutter blades:

- 1 Turn off the machine.
- 2 Remove the back cover, and then remove the tape cassette if one is installed. The tape cutter is located near the tape exit slot.
- 3 Using a cotton swab dipped in isopropyl (rubbing) alcohol or ethanol, wipe the tape cutter blades with an up-and-down motion.

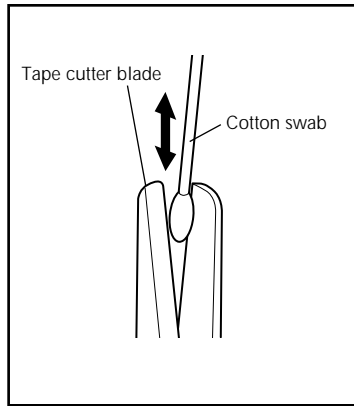
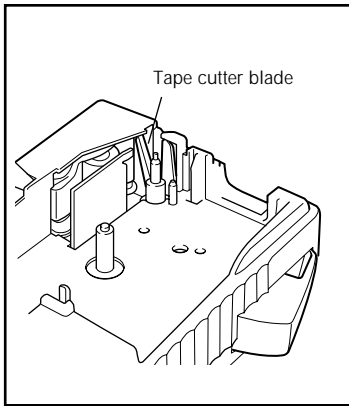

 **Be careful not to touch the cutter blades with bare hands.**

CARRYING CASE

The enclosed hard case is designed to protect your P-touch and its accessories while you store or carry them. Therefore, keep them in this carrying case whenever they are not being used.

Before opening the carrying case, be sure that the side with the "brother P-touch" logo faces upward.

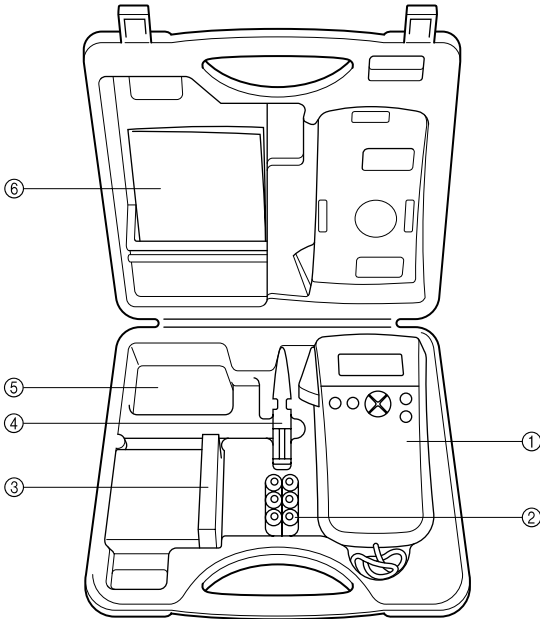

- ① P-touch Model PT-1300
- ② Six AA batteries
- ③ Tape cassettes

☞ Stand up the tape cassettes so that the end with the label attached faces upwards.

This compartment can store up to five 1/4" (6-mm)-, 3/8" (9-mm)- or 1/2" (12-mm)-wide tape cassettes, four 3/4" (18-mm)-wide tape cassettes, or a combination of three 1/2" (12-mm)- and two 3/4" (18-mm)-wide tape cassettes.

- ④ Tape separator
- ⑤ AC adapter

☞ *This compartment can store the optional AC adapter (model AD-60), designed exclusively for the PT-1300.*

- ⑥ User's Guide

*For your
information*

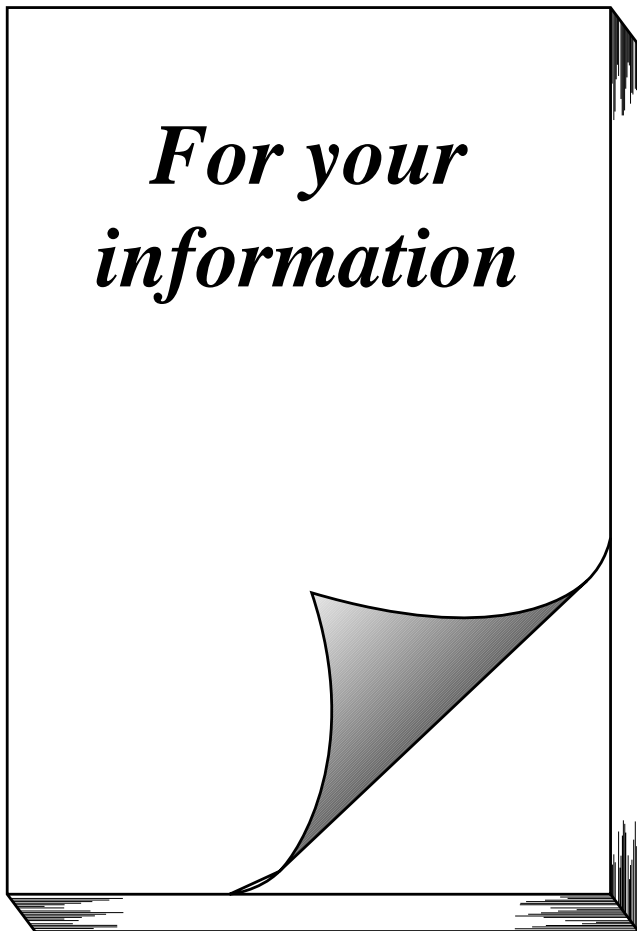

POWER KEY

The power key () is located in the top right-hand corner of the keyboard. If batteries have been installed or the machine has been plugged in using the optional AC adapter, the previous session's information is displayed when the machine is turned on. This feature allows you to stop work on a label, turn off the machine, and return to it later without having to re-enter the text.

The machine will automatically turn off if no key is pressed within 5 minutes. The machine's internal memory stores the current session's information and displays it when you turn on the machine again.

To turn on the machine:

- Press . The previous session's information appears in the LCD display.

To turn off the machine:

- Press . The current session's information is stored in the internal memory.

CODE & CAPS KEYS

Most characters can be entered simply by pressing their keys. However, to use special functions or to enter capital letters, accented characters and some symbols, the following special keys are necessary.

CODE KEY

To use a function or type in characters printed either above or below a key:

- Hold down  and press the key either immediately below or immediately above the desired function or character written in orange.

EXAMPLE

To start the accent function:

- Hold down  and press  once.

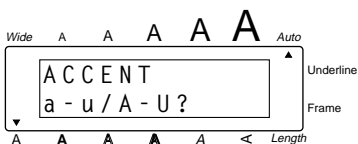

CAPS KEY

To type capital letters continuously:

- 1 Press **Caps** until the **Caps** indicator (**Caps**) on the left side of the display lights up.
- 2 Press the keys of the desired letters.
*To exit **Caps** mode, press **Caps** until the **Caps** indicator goes off.*

EXAMPLE

To type in "JOHN":



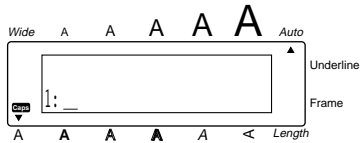

- 1 Press **Caps** once.

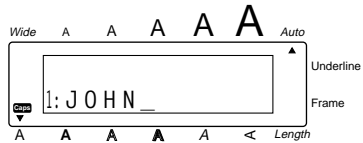

- 2 Press **J**, **O**, **H**, then **N** once each.



CURSOR KEYS

The machine's LCD display shows two rows of 11 characters; however, the text that you create can be up to 99 characters long. You can review and edit your text by using the cursor keys (, , , ) to move the cursor so that different parts are shown in the display.

LEFT CURSOR KEY



To move the cursor one character to the left:

- Press  once.

To move the cursor several characters to the left:

- Hold down  until the cursor moves to the desired position.

To move the cursor to the beginning of the current line:

- Hold down  and press .

RIGHT CURSOR KEY

To move the cursor one character to the right:

- Press  once.

To move the cursor several characters to the right:

- Hold down  until the cursor moves to the desired position.

To move the cursor to the end of the current line:

- Hold down  and press .

UP CURSOR KEY



To move the cursor up to the previous line:

- Press  once.

To move the cursor up several lines:

- Hold down  until the cursor moves to the desired position.

To move the cursor to the beginning of the entire text:

- Hold down  and press .

DOWN CURSOR KEY



To move the cursor down to the following line:

- Press  once.

To move the cursor down several lines:

- Hold down  until the cursor moves to the desired position.

To move the cursor to the end of the entire text:

- Hold down  and press .

SPACE KEY

The **Space** key lets you add blank spaces between characters in your text. It is different from the right cursor key ($\langle \rangle \rightarrow$), which just moves the cursor without adding blank spaces.

To add a space:

- Press **Space**.

EXAMPLE

To add a space:

- Press **Space**.

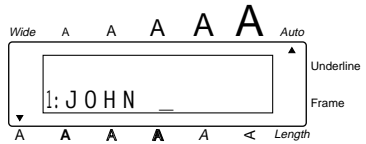

RETURN KEY

Like on a typewriter or word processor, this machine's return key ( ^{Memory}) is used to end a line of text and start another one. When you have finished entering one line of text, press the return key to add a return mark (↵) to the end of the line and start a new one.

☞ *A maximum of four text lines can be entered. If you press  ^{Memory} when the cursor is located in the fourth line, the error message "4 LINE LIMIT!" will appear.*

The number of text lines that can be printed on the installed tape depends on the tape width.

Tape width	Maximum number of lines that can be printed
1/4" (6 mm)	1
3/8" (9 mm)	2
1/2" (12 mm)	2
3/4" (18 mm)	4







The return key can also be used to select an item from a list (e.g., add a symbol or accented character to the text) or to apply a selected setting.

Some question asking you to confirm a command may appear on the LCD display, especially when the function that you have chosen will delete or affect text. In these

cases, pressing  ^{Memory} is the same as answering "yes".

☞ *To answer "no", press  ^{Clear}. Refer to BACKSPACE KEY on pages 25 and 26.*

To add a new line:

- 1 Press , ,  or  to position the cursor to the right of the character that will end the line.
- 2 Press . The return mark () appears at the end of the line and the cursor moves to the new line.

EXAMPLE

To add a second line:

- Press .

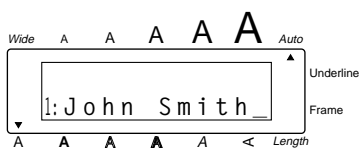

To apply a selected item:

- Press ^{Memory}  once.

EXAMPLE

To add “” to your text:

- Press ^{Memory}  once.

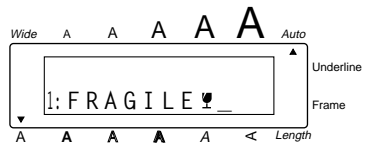
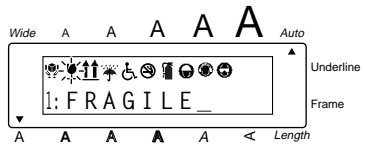

BACKSPACE KEY

The backspace key (BS) allows you to remove characters to the left of the cursor's current position. It differs from the left cursor key (\leftarrow), which only moves the cursor without deleting any characters.

The backspace key can also be used to quit most functions and return to the previous display without changing the text.

*The backspace key cannot be used to quit the **barcode** function. To quit the **barcode** function, hold down Code and press N .*

Some questions asking you to confirm a command may appear on the LCD display, especially when the function that you have chosen will delete or affect text. In these cases, pressing BS is the same as answering "no".

To answer "yes", press Memory . Refer to RETURN KEY on pages 22 to 24.

To delete one character:

- 1 Press \leftarrow , \rightarrow , Home or End to position the cursor below the character immediately to the right of the one that you wish to delete.
- 2 Press BS once.

To delete a sequence of characters:

- 1 Press \leftarrow , \rightarrow , Home or End to position the cursor below the character immediately to the right of the last character that you wish to delete.
- 2 Hold down BS until all of the characters that you wish to delete are deleted.

EXAMPLE

To delete "9":

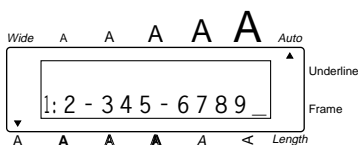

- 1 Press  once.

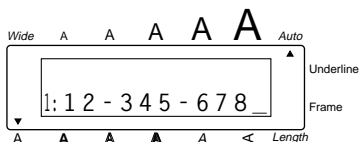

To delete "-678":

- 2 Hold down  until "-678" are deleted.

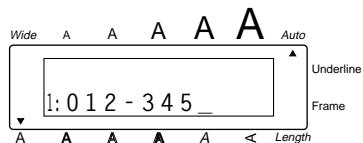

To quit a function without changing your text:

- Press  to return to your text.

EXAMPLE

To quit the symbol function without adding a symbol to your text:



- Press .

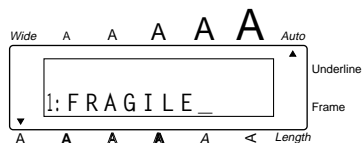

CLEAR FUNCTION

The **clear** function is used to remove all characters from the display so that you can begin entering new text. Although all of the text is erased, the **Caps** mode and the character format settings (**size**, **width**, **style**, **underline** and **frame** functions) do not change.

To delete all of the text:

- Hold down **Code** and press **BS**^{Clear}. All of the text is erased from the display.

EXAMPLE

To clear the display:

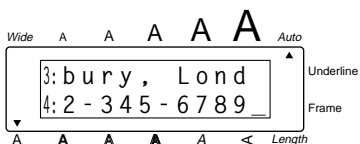

- Hold down **Code** and press **BS**^{Clear}.

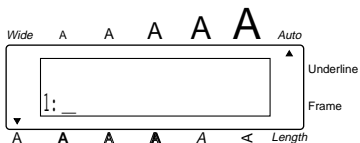

ACCENT FUNCTION

The **accent** function can be used to add accented characters to your text. The accented characters are grouped according to the capital or lowercase letter that they are combined with. The following accented characters are available:

Letter	Accented characters	Letter	Accented characters
a	à á â ã ä å æ	l	ĺ ł
A	À Á Â Ã Ä Å Æ	n	ñ
c	ç	N	Ñ
C	Ç	o	ó ô õ ö
e	è é ê ë ì	O	Ó Ô Õ Ö
E	È É Ê Ë Ì	u	ù ú û ü
i	í î	U	Û Ü Û Ü

☞ Some of these accented characters can be typed in using the **symbol** function (refer to pages 30 and 31).

To type in an accented character:

① Hold down **Code** and press **Accent** (O). The message "ACCENT a-u/A-U?" appears on the display.

② Press the key of the letter in the desired accented character.

☞ If you wish to type in a capital letter, press **Caps** to enter **Caps** mode (the **Caps** indicator lights up) before pressing the letter key.

③ Press **<<** or **>>** until the desired accented character flashes.

④ Press **Memory** (↵). The accented character is added to the text.

☞ To type in a series of accented characters, hold down **Code** before pressing **Memory** (↵). Then, continue adding accented characters by selecting them as explained in steps ② and ③, and holding down **Code** while pressing **Memory** (↵). Press just **Memory** (↵) after selecting the last character in the series.

EXAMPLE

To add the accented character “Ë”:

- 1 Hold down **Code** and press **Accent**.

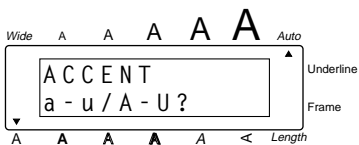

- 2 Press **Caps**.

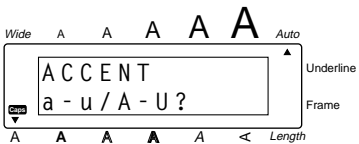

- 3 Press **Margin**.

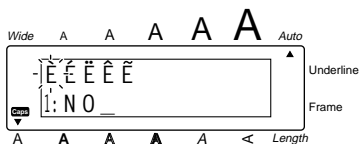

- 4 Press **>>>** until “Ë” flashes.

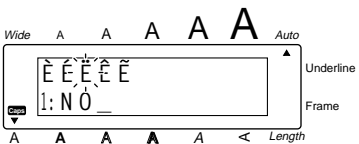



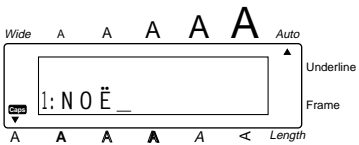



















- 5 Press **Memory**.













SYMBOL FUNCTION

In addition to the letters, symbols and numerals on the key tops, there are 46 additional marks available with the **symbol** function. These symbols are divided into the four groups shown below.

Symbols											
Ü	Æ	æ	Ã	ã	Ě	ě	Õ	õ	TM	®	©
+	×	÷	=	§	2	3	2	3	4	★	•
											
											

To type in a symbol:

- 1 Press . A row of symbols appears in the display.
- 2 Press  or  to display different rows of symbols, and press  or  until the desired symbol flashes.
- 3 Press . The symbol appears in the text.





⇒ To type in a series of symbols, hold down  before pressing . Then, continue adding symbols by selecting them as explained in steps 2 and 3, and holding down  while pressing . Press just  after selecting the last symbol in the series.

EXAMPLE

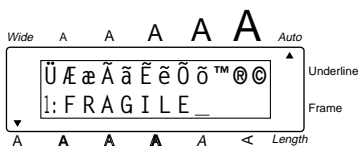
To add the symbol “☪”:

① Press .



② Press  or  until the row containing “☪” appears, and then press  or  until “☪” flashes.

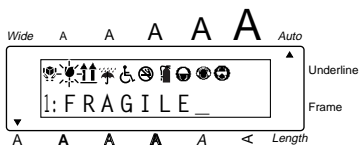

③ Press .









LENGTH FUNCTION

Although the length of the printed label automatically adjusts to fit the length of the entered text, there may be times when you will want to make a label with a specific length. The **length** function allows you to set the label length between 1.6 and 11.8 inches (4.0 and 30.0 centimeters).







The default length setting is **OFF**. If **ON** is selected, the **Length** indicator at the bottom of the display lights up.

☞ *Turning off the machine and then turning it on again changes the length setting back to **OFF**.*

To turn on or off the length function:

- 1 While holding down , press  once, and keep  held down to display the current length of the label (the text and both margins) briefly, then display the current label length setting (**ON** or **OFF**).
- 2 While still holding down , continue pressing  until the desired label length setting is displayed.
☞ *The **Length** indicator lights up when **ON** is selected.*
- 3 Release . If **ON** was selected, the current label length setting is displayed.

To set the length of the label:



- 4 Press  or  to select the desired length or use the number keys to enter a length.
☞ *To change the length in 1" (1.0 cm) steps, hold down either  or , and then release the key when the desired setting is displayed.
The default setting (3.9" (10.0 cm)) can be selected by pressing .*
- 5 Press .

EXAMPLE

To select a label length of 5.2”:

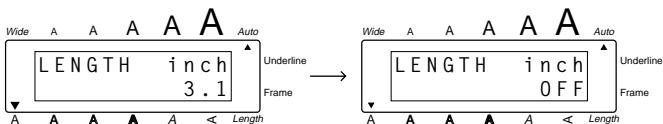
- 1 Hold down  and press  once.



- 2 Keep  held down and continue pressing  until **ON** is displayed.

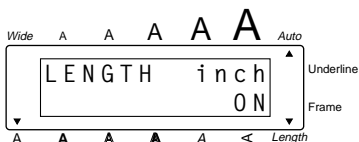

- 3 Release .

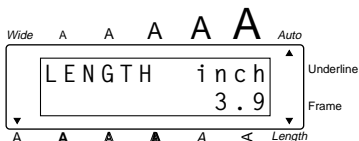

- 4 Press  until **5.2** is displayed.

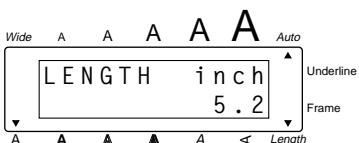

- 5 Press .

SIZE & WIDTH FUNCTIONS

The character size of the entire text can be adjusted using both the **size** and **width** functions. Since the character size that can be used depends on the width of the tape, the following table shows the character sizes that can be used with each tape width.

Tape width	Sizes (in points)
1/4" (6 mm)	12, 9
3/8" (9 mm)	18, 12, 9
1/2" (12 mm)	24, 18, 12, 9
3/4" (18 mm)	36, 24, 18, 12, 9

The default size setting is **AUTO** and the default width setting is **OFF**. The currently selected size setting is always shown by the indicators at the top of the display. When the **ON** width setting is selected, the **Wide** indicator at the top-left corner of the display lights up.

With the **AUTO** size setting, the machine compares your text with the width of the installed tape and automatically adjusts the characters to the largest size possible. However, five other point sizes are also available and each can be printed in wide characters.

Size setting (in points)	Width setting OFF	Width setting ON
36 (A)	ABC	ABC
24 (A)	ABC	ABC
18 (A)	ABC	ABC
12 (A)	ABC	ABC
9 (A)	ABC	ABC

☞ If the **AUTO** size setting is selected and only one line of characters has been entered, the text can be printed with a character size slightly larger than the maximum for the installed tape under any of the following conditions.

- 1/2" (12-mm)- or 3/4" (18-mm)-wide tape is installed and the text contains only capital letters
- 3/4" (18-mm)-wide tape is installed and the characters are not formatted (i.e., the **style**, **underline** or **frame** setting is not applied)

Tape width \ Text lines	1/4" (6 mm)	3/8" (9 mm)	1/2" (12 mm)	3/4" (18 mm)
1	12 pts	18 pts	All caps: 29 pts Not all caps: 24 pts	All caps, not formatted: 57 pts All caps, formatted: 45 pts Not all caps, not formatted: 45 pts Not all caps, formatted: 36 pts
2	N/A	9 pts	12 pts	18 pts
3	N/A	N/A	N/A	12 pts
4	N/A	N/A	N/A	9 pts

To change the size setting:

- 1 While holding down **Code**, press **Size 1** once, and keep **Code** held down to display the current size setting.
- 2 While still holding down **Code**, continue pressing **Size 1** until the desired size setting is displayed.

☞ The current character size setting is also shown by the size indicators above the display.
- 3 Release **Code** to apply the selected size setting to the entire text.

EXAMPLE

To select the 24 point size setting:

- 1 While holding down **Code**, press **Size 1** once, and keep **Code** held down.

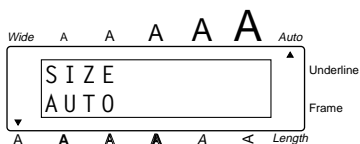

To select the 24 point size setting:

- 1 While still holding down **Code**, continue pressing **Size 1** until **24** is displayed.

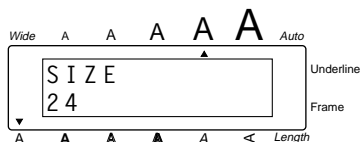

- 2 Release **Code**.

To change the width setting:

- 1 While holding down **Code**, press **Width 3** once, and keep **Code** held down to display the current width setting.
- 2 While still holding down **Code**, continue pressing **Width 3** until the desired width setting is displayed.
*☞ The **Wide** indicator lights up when the **ON** setting is selected.*
- 3 Release **Code** to apply the selected width setting to the entire text.

EXAMPLE

To select the ON width setting:

- 1 While holding down **Code**, press **Width 3** once, and keep **Code** held down.

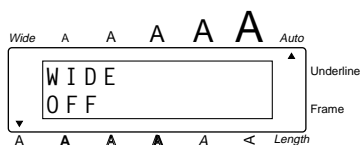

- 2 While still holding down **Code**, continue pressing **Width 3** until **ON** is displayed.

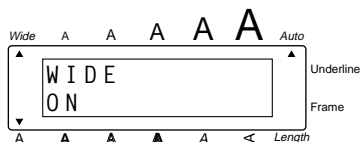

- 3 Release **Code**.

STYLE FUNCTION

You can choose from nine different character styles to apply to your text.

The following style settings are available:

NORMAL (A)

ABC

ITALIC (A + A)

ABC

BOLD (A)

ABC

I+BOLD (A + A)

[italic & bold]

ABC

OUTLINE (A)

ABC

I+OUTLINE (A + A)

[italic & outline]

ABC

SHADOW (A)

ABC

I+SHADOW (A + A)

[italic & shadow]

ABC

VERTICAL (<)

◀ m o

The default style setting is **NORMAL**. The style indicators at the bottom of the display show the current style setting.

☞ *Characters printed using the smaller sizes may be difficult to read if certain style settings (e.g., **I+SHADOW**) are selected.*

To change the style setting:

- 1 While holding down **Code**, press **Style 5** once, and keep **Code** held down to display the current style setting.
- 2 While still holding down **Code**, continue pressing **Style 5** until the desired style setting is displayed.
☞ The current style setting is shown by the style indicators at the bottom of the display.
- 3 Release **Code** to apply the selected style setting to the entire text.

EXAMPLE

To select the BOLD style setting:

- 1 While holding down **Code**, press **Style 5** once, and keep **Code** held down.



- 2 While still holding down **Code**, continue pressing **Style 5** until **BOLD** is displayed.

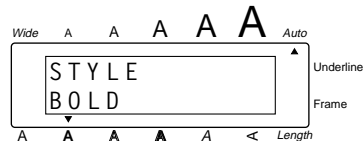

- 3 Release **Code**.

UNDERLINE FUNCTION

You can add emphasis to your text by underlining it.

The default underline setting is **OFF**. When the **underline** function is set to **ON**, the **Underline** indicator on the right side of the display lights up.

☞ If a frame has been chosen while the **ON** underline setting is selected, the frame setting changes back to **OFF** and the text is underlined.

OFF



ON



To change the underline setting:

- 1 While holding down **Code**, press **Underline** (7) once, and keep **Code** held down to display the current underline setting.
- 2 While still holding down **Code**, continue pressing **Underline** (7) until the desired underline setting is displayed.
☞ The **Underline** indicator lights up when the **ON** setting is selected.
- 3 Release **Code** to apply the selected underline setting to the entire text.

EXAMPLE

To select the ON underline setting:

- 1 While holding down **Code**, press **Underline** (7) once, and keep **Code** held down.
- 2 While still holding down **Code**, continue pressing **Underline** (7) until **ON** is displayed.
- 3 Release **Code**.

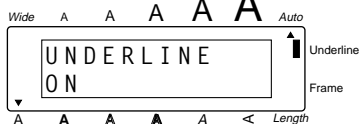

FRAME FUNCTION

With the **frame** function, you can choose from various frames and highlights to make more decorative or emphasized text.

The following frame settings are available:

OFF

ABC

ROUND

ABC

DOT

ABC

DIAMOND

ABC

SLANT

ABC

The default frame setting is **OFF**. When any setting other than **OFF** is selected, the **Frame** indicator on the right side of the display lights up.

☞ *If the **ON** underline setting has been chosen when a frame is selected, the underline setting changes back to **OFF** and the text is framed.*

To change the frame setting:

- 1 While holding down **Code**, press **9**^{Frame} once, and keep **Code** held down to display the current frame setting.
- 2 While still holding down **Code**, continue pressing **9**^{Frame} until the desired frame setting is displayed.
☞ *The **Frame** indicator lights up when any setting other than **OFF** is selected.*
- 3 Release **Code** to apply the selected frame setting to the entire text.

EXAMPLE

To select the DOT frame setting:

- 1 While holding down **Code**, press **9** once, and **Code** keep held down.

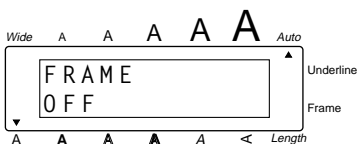

- 2 While still holding down **Code**, continue pressing **9** until **DOT** is displayed.

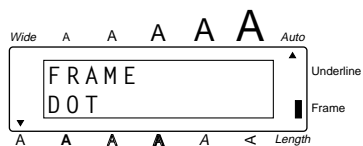

- 3 Release **Code**.

TAPE MARGIN FUNCTION

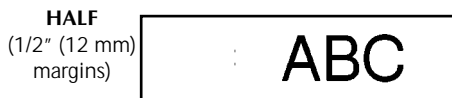
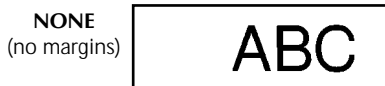

The **tape margin** function allows you to adjust the size of the margins on the left and right sides of your text. In addition, the **NONE** tape margin setting can be used to print one label with many different format styles.

The default tape margin setting is **FULL**; however, two other settings are also available.



☞ If an instant-lettering (rub-on) or iron-on tape cassette is installed, the text will be printed with the **FULL** setting (1" (24 mm) margins), even if a different tape margin setting is selected.

After printing a label with the **tape margin** function set to **NONE**, hold down

 and press  once to feed the tape before pressing in the tape cutter lever to cut it, otherwise some of the printed characters may be cut off as shown below.



After printing using the **HALF** tape margin setting, press in the tape cutter lever to cut off the label, and then use scissors to cut along the printed dots (:) to center the text within the label.

To change the tape margin setting:

- 1 While holding down **Code**, press **Margin E** once, and keep **Code** held down to display the current tape margin setting.
- 2 While still holding down **Code**, continue pressing **Margin E** until the desired tape margin setting is displayed.
- 3 Release **Code** to apply the selected tape margin setting to the text.

EXAMPLE

To make a label using different styles with the tape margin function set to NONE:

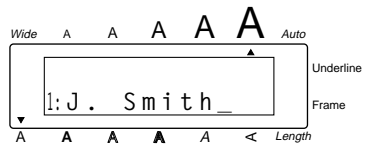

- 1 While holding down **Code**, press **Margin E** once, and keep **Code** held down.

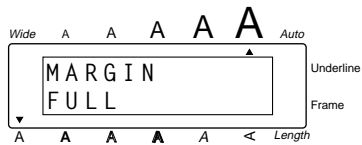

- 2 While still holding down **Code**, continue pressing **Margin E** until **NONE** is displayed.

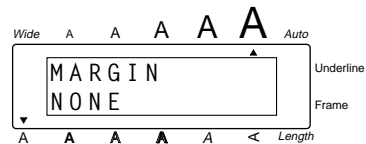

- 3 Release **Code**.

4 Press .

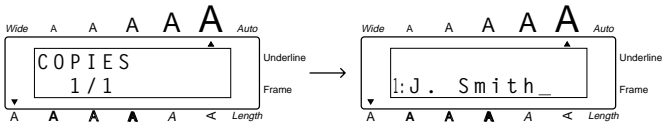

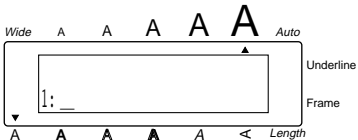

5 Hold down  and press .



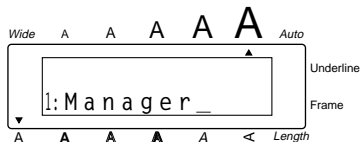

6 Type in "Manager".

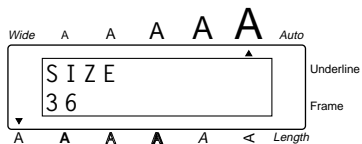

7 While holding down , press  once, and keep  held down.



8 While still holding down , continue pressing  until 12 is displayed.

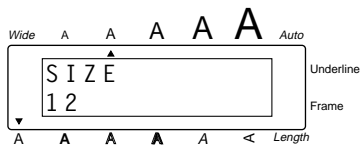

9 Release .

10 Press .

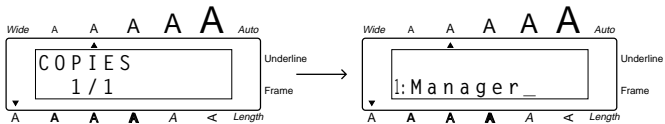

11 Hold down  and press .

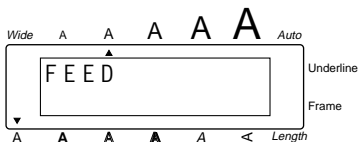

12 Press in the tape cutter lever to cut the tape.

J. Smith Manager

HORIZONTAL ALIGNMENT FUNCTION

You can choose to align lines in the text in one of three ways. In addition, if the **length** function was used to set the length of the label, the text will align within the label according to the selected horizontal alignment setting.

The default horizontal alignment setting is **LEFT**; however, two other settings are also available:

LEFT	AB CDE FG	CENTER	AB CDE FG	RIGHT	AB CDE FG
-------------	-----------------	---------------	-----------------	--------------	-----------------

To change the horizontal alignment setting:

- 1 While holding down **Code**, press **Align T** once, and keep **Code** held down to display the current horizontal alignment setting.
- 2 While still holding down **Code**, continue pressing **Align T** until the desired horizontal alignment setting is displayed.
- 3 Release **Code** to apply the selected horizontal alignment setting to the entire text.

EXAMPLE

To select the **RIGHT** horizontal alignment setting:

- 1 While holding down **Code**, press **Align T** once, and keep **Code** held down.



- 2 While still holding down **Code**, continue pressing **Align T** until **RIGHT** is displayed.



- 3 Release **Code**.

MIRROR PRINTING FUNCTION

With this function, you can print your text so that the characters can be read from the adhesive side of the tape. If mirror-printed labels are attached to glass or some other clear material, they can be read correctly from the opposite side.

☞ When using the **mirror printing** function, the text should be printed on clear tape.

The default mirror printing setting is **OFF**.

OFF



ON



To change the mirror printing setting:

- 1 While holding down **Code** and press **Mirror U** once, and keep **Code** held down to display the current mirror printing setting.
- 2 While still holding down **Code**, continue pressing **Mirror U** until the desired mirror printing setting is displayed.
- 3 Release **Code** to apply the selected mirror printing setting to the entire text.

EXAMPLE

To select the ON mirror printing setting:

- 1 While holding down **Code**, press **Mirror U** once, and keep **Code** held down.

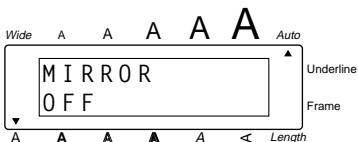

- 2 While still holding down **Code**, continue pressing **Mirror U** until **ON** is displayed.

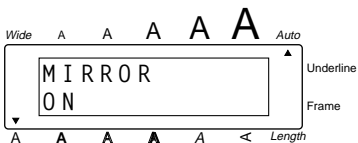

- 3 Release **Code**.

BARCODE FUNCTION

The **barcode** function, which enables barcodes to be printed as part of labels, is one of this machine's most advanced features.

☞ *This section will explain how to enter a barcode into your text. It is not intended as a comprehensive introduction to the concept of barcoding. For more detailed information, please consult one of the many reference books available.*

"Since barcode scanner performance varies from manufacturer and model types, some barcode scanners may not be able to read the labels."

Print barcodes with black ink on a white background.

Four different parameters enable you to create custom barcodes.

Parameter	Settings
PROTOCOL	CODE 39, CODE128, EAN128, CODABAR, UPC-E, UPC-A, EAN8, EAN13, I-2/5
WIDTH (barcode width)	LARGE, SMALL
UNDER#S (numbers printed below barcode)	ON, OFF
CHECK DIG. (check digit)	OFF, ON

The default settings are **CODE 39 PROTOCOL**, **LARGE WIDTH**, **UNDER#S** set to **ON**, and **CHECK DIG.** set to **OFF**.

☞ *We recommend that barcodes be printed with the **tape margin** function set to **FULL** and the barcode **WIDTH** parameter set to **LARGE**; otherwise, the barcodes may be difficult to read.*



Barcodes must be entered according to the following rules:



Protocol	Number of digits (including check digits and start and stop codes)	Characters that can be used	Notes
CODE 39	4 through 22	Numbers, letters, spaces, and symbols -, \$, ., /, +, and %	The asterisk (*) is not needed as start and stop codes.
CODE128	4 through 22	All ASCII characters.	



Protocol	Number of digits (including check digits and start and stop codes)	Characters that can be used	Notes
EAN128	4 through 22	All ASCII characters	
CODABAR	4 through 22	Numbers, letters, and symbols -, \$, :, /, ., and +	Start and stop codes must be A, B, C, or D
UPC-E	6	Numbers	
UPC-A	13	Numbers	
EAN8	8	Numbers	
EAN13	13	Numbers	
I-2/5	Even number of digits*	Numbers	



* Two digits are needed to print each part of the data for an I-2/5 barcode. Therefore, if an odd number of digits are entered, "0" is automatically added at the beginning of the data when the barcode is printed. However, "0" does not appear on the LCD display.

To use the barcode function:

- Hold down  and press .

☞ To change the data or parameters of a barcode that has already been created, position the cursor below the barcode mark (||||) before holding down  and pressing .

A label can only contain one barcode. If a barcode has already been entered when  is held down and  is pressed, the error message "1 BAR CODE / LABEL" will appear.





To quit the **barcode** function without making any changes, hold down  and press .

- Type in the new barcode data or edit the old data.





To change the barcode parameter settings:

- Press .

☞ To return to the barcode data display without changing any parameter settings, press .

- 4 Press  or  until the parameter that you wish to change appears.
- 5 Press  or  until the desired setting is displayed.
- 6 Repeat steps 4 and 5 until all parameters are set as you wish.
- 7 Press .

To add a special character to the barcode data:

- 8 Press  or  until the cursor is below the character immediately to the right of where you want to add special character.
- 9 Press .
- 10 Press  or  until the desired special character is displayed.

☞ The following special characters can only be entered when using protocols **CODE 39** or **CODABAR**.

Symbol	Character
1	+
2	\$

The following special characters can only be entered when using protocols **EAN 128** and **CODE128**.

VALUE	SPECIAL CHARACTER	VALUE	SPECIAL CHARACTER	VALUE	SPECIAL CHARACTER
3	#	69	ENQ	87	ETB
4	\$	70	ACK	88	CAN
11	+	71	BEL	89	EM
28	<	72	BS	90	SUB
29	=	73	HT	91	ESC







VALUE	SPECIAL CHARACTER	VALUE	SPECIAL CHARACTER	VALUE	SPECIAL CHARACTER
30	>	74	LF	91	{
32	@	75	VT	92	FS
59	[76	FF	92	
60	\	77	CR	93	GS
61]	78	SO	93	}
62	^	79	SI	94	RS
63	_	80	DLE	94	~
64	NUL	81	DC1	95	US
64	`	82	DC2	95	DEL
65	SOH	83	DC3	96	FNC 3
66	STX	84	DC4	97	FNC 2
67	ETX	85	NAK	100	FNC 4
68	EOT	86	SYN	102	FNC1

- 11 Press  to add the selected special character to the barcode data.

To add the barcode to your text:

- 12 Press .

To delete the barcode from your text:

- 1 Press , ,  or  until the cursor is positioned either below the right half of the barcode mark or immediately to the right of the entire barcode mark.
- 2 Press . The message "OK TO CLEAR? ||| |||".
- 3 Press .

EXAMPLE

To add a barcode to the label:

- 1 Hold down **Code** and press **N**.
Barcode

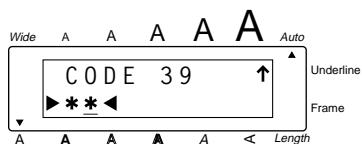

- 2 Press **Home**.

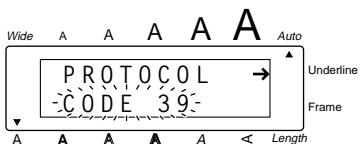

- 3 Press **>** until the **CHECK DIG.** parameter is displayed.



- 4 Press **Home** or **End** until **ON** is displayed.



- 5 Press **Memory**.



6 Press **Size** 1, **@** 2, **Width** 3, **\$** 4, then

Style
5

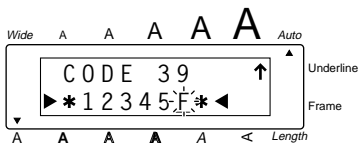

7 Press **Memory** ↵





PRINT KEY & FEED FUNCTION

After you have entered your text and chosen the desired format settings, you are ready to print the label.



To print a label:

- Press  once. The message "COPIES 1/1" is displayed while the label is being printed. The label is fed out of the tape exit slot at the top end of the machine.

☞ After printing with the **tape margin** function set to **NONE**, hold down

 and press  once to feed the tape before cutting it, otherwise some of the printed characters may be cut off.

To feed the tape:

- Hold down  and press . The message "FEED" appears while 1" (24 mm) of tape is fed out.

To cut the tape:

- Press in the tape cutter lever.
☞ In order to prevent damaging the tape, do not try to cut it while printing or feeding.
Pressing in the tape cutter lever too far may break it.

EXAMPLE

To make a label with the tape margin function set to NONE:

- 1 Press  once.



- 2 Hold down  and press  once.
- 3 Press in the tape cutter lever.

NUMBERING FUNCTION

This function can be used to print many copies of the same text while increasing a certain number in the text by 1 after each label is printed. This type of automatic incrementation is very useful when printing serial number labels, production control labels or other labels requiring ascending codes.

To use the numbering function:

- 1 Press \leftarrow (Left Arrow), \rightarrow (Right Arrow), Home or End to position the cursor below the number that you wish to increase.
- 2 Hold down Code and press V (Number). The message "NUMBER UNTIL 1-9?" appears in the display.

*To quit the **numbering** function without printing, hold down Code and press V (Number) (or press just Clear BS).*

- 3 Press the number key ($\text{Size } 1$ to $\text{Frame } 9$) of the last number that is to be printed.
- 4 Press Print (or Memory) to begin printing the labels. The number of each copy is displayed while it is being printed.

*After printing with the **tape margin** function set to **NONE**, hold down Code and press Feed (Sym.) once to feed the tape before cutting it, otherwise some of the printed characters may be cut off.*

- 5 Press in the tape cutter lever to cut the tape, and then use scissors to cut along the printed dots to separate the labels.

EXAMPLE

To print three door labels for studios 1, 2 and 3:

- 1 Position the cursor below "1".



- 2 Hold down **Code** and press **V** (Number).

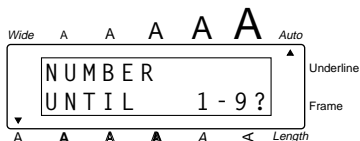

- 3 Press **3** (Width).

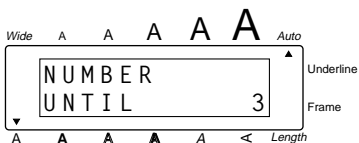

- 4 Press **Print** (or **Memory**).

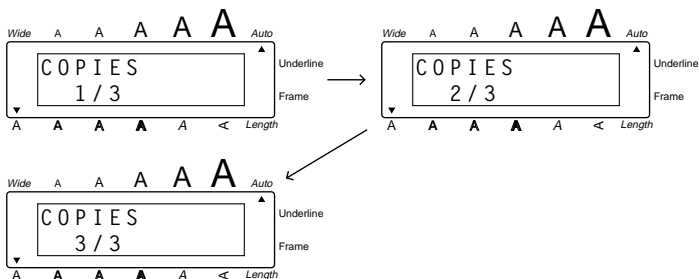

- 5 Press in the tape cutter lever to cut the tape, and then use scissors to cut along the printed dots to separate the labels.



REPEAT PRINTING FUNCTION

This function allows you to print up to 9 copies of the same text.

To use the repeat printing function:

- 1 Hold down **Code** and press **X** (Repeat). The message "COPIES UNTIL 1-9?" appears in the display.
*To quit the **repeat printing** function without printing, hold down **Code** and press **X** (Repeat) (or press just **Clear BS**).*
- 2 Press the number key (**Size** **1** to **Frame** **9**) of the number of labels that you want.
- 3 Press **Print** (or **Memory**) to begin printing the labels. The number of each copy is displayed while it is being printed.
*After printing with the **tape margin** function set to **NONE**, hold down **Code** and press **Feed** **Sym.** once to feed the tape before cutting it, otherwise some of the printed characters may be cut off.*
- 4 Press in the tape cutter lever to cut the tape, and then use scissors to cut along the printed dots to separate the labels.

EXAMPLE

To print three copies of a label:

- 1 Hold down **Code** and press **X** (Repeat).



- 2 Press .



- 3 Press  (or .

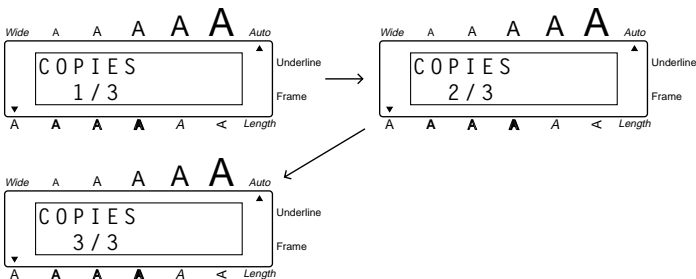

- 4 Press in the tape cutter lever to cut the tape, and then use scissors to cut along the printed dots to separate the labels.

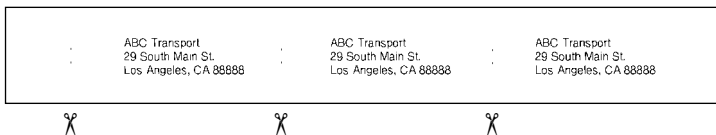

MEMORY FUNCTIONS

You can use the memory to store your most frequently used text files. The text remains in the memory, even after all characters are removed from the display using the **clear** function (see page 27).



When a file is stored, it is given a number to make recalling it easier. A maximum of 9 text files or about 300 characters can be stored in the memory. A stored text file can contain a maximum of 99 characters.



Since a copy of the stored text file is recalled when the **recall** function is used, the text can be edited or printed without changing the originally stored file. When a file is no longer needed or more space is necessary, the **memory delete** function can be used to delete it.

☞ *When inserting new batteries, be sure to insert the new ones within five minutes of removing the old ones, otherwise any text files stored in the memory will be lost (unless the machine is plugged into an electrical outlet with the AC adapter).*

STORING TEXT



To store a text file:



1 Hold down  and press .

2 Press  or  until **STORE** flashes on the display.

3 Press . The message "STORE SELECT 1-9?" appears on the display.



☞ *If 300 characters have already been stored, the error message "MEMORY FULL!" appears in the display. If this occurs, an existing text file must be deleted before the new one can be stored.*

To quit the **store** function without storing the text, hold down  and press  (or press just .

4 Press the key ( to ) of the file number where you wish to store the text. The text is stored under the selected file number and the text previously shown in the display reappears.















☞ *If a file is already stored under the selected file number, the message "OVERWRITE?" appears in the display and you must decide whether or not to overwrite it (delete it from the memory and store the new one).*

To overwrite the stored file with the new one:

- Press  to delete the previously stored file and store the new one under the selected number.
 - ☞ To go back and choose another file number without overwriting the text file, press , and then select a different file number.





RECALLING TEXT

To recall a text file:

- 1 Hold down  and press .
- 2 Press  or  until **RECALL** flashes on the display.
- 3 Press . The message "RECALL SELECT 1-9?" appears on the display.
 - ☞ To quit the **recall** function without recalling the text file, hold down  and press  (or press just ).
- 4 Press the key ( to ) of the file number containing the text that you wish to recall. The text stored under the selected file number is shown.
 - ☞ To see other parts of the displayed text file, press  or .
 - To display the text stored under other file numbers, press  or , or the key of a different file number.
- 5 Press . Any text previously entered in the display is erased and the text stored under the selected file number is recalled into the display.

DELETING A FILE

To delete a text file:

- 1 Hold down  and press .
- 2 Press  or  until **CLEAR** flashes on the display.
- 3 Press . The message "CLEAR SELECT 1-9?" appears on the display.

☞ To quit the **memory delete** function without deleting the text file, hold down **Code** and press **Memory** (or press just **Clear BS**).

- 4 Press the key (**Size** **1** to **Frame** **9**) of the file number containing the text that you wish to delete. The text stored under the selected file number is shown.

☞ To see other parts of the selected text file, press **<<** or **>>**.

To display the text stored under other file numbers, press **Home** or **End**, or the key of a different file number.

- 5 Press **Memory** to delete the text file that was selected.

EXAMPLE

To store text under file number 8:

- 1 Hold down **Code** and press **Memory**.



- 2 Press **Memory**.

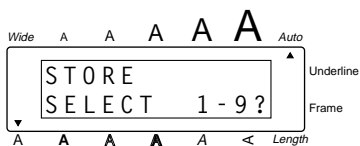

- 3 Press **8**.



To recall the text from file number 4:

- 1 Hold down **Code** and press **Memory**.



- 2 Press **>>>** until **RECALL** flashes on the display.



- 3 Press **Memory**.

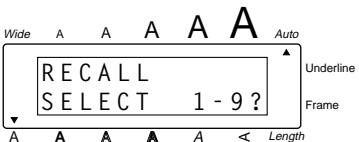

- 4 Press **S**.



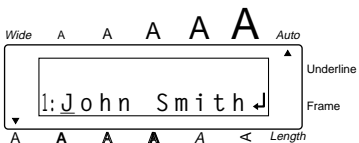

- 5 Press **Memory**.

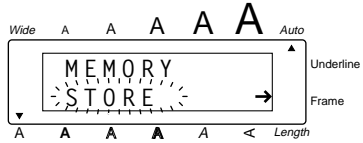

To delete the text stored under file number 8:

- 1 Hold down  and press .



- 2 Press  until **CLEAR** flashes on the display.

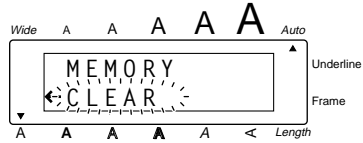

- 3 Press .

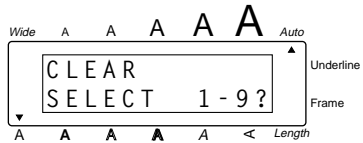

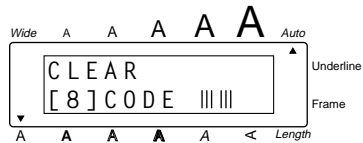

- 4 Press .



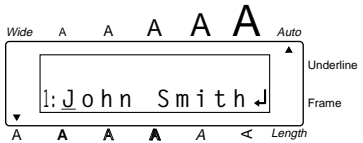







- 5 Press .











TROUBLESHOOTING

Problem	Remedy
1. The display stays blank after you have turned on the machine.	<ul style="list-style-type: none"> • Check that the correct AC adapter (AD-60) is being used and that it is connected correctly. • If you are using alkaline batteries, check that they are correctly inserted. • If the batteries are low, replace them with new ones.
2. The machine does not print or the printed characters are blurred.	<ul style="list-style-type: none"> • Check that the correct AC adapter (AD-60) is being used and that it is connected correctly. • Check that the tape cassette has been inserted properly. • If the tape cassette is empty, replace it with a new one. • Make sure that the back cover has been attached.
3. The text files that you stored in the memory are no longer there.	<ul style="list-style-type: none"> • If the batteries are low, replace them with new ones.
4. The printed characters are not formed properly.	<ul style="list-style-type: none"> • If you are using alkaline batteries, they may be low. Try using the AC adapter or replace the batteries with new ones. • Check that the correct AC adapter (AD-60) is being used and that it is connected correctly.
5. A blank horizontal white line appears through the printed label.	<ul style="list-style-type: none"> • Clean the print head as explained on page 10 and 10.
6. Striped tape appears.	<ul style="list-style-type: none"> • You have reached the end of the tape. Replace the tape cassette with a new one.
7. The machine has "locked up" (i.e., nothing happens when a key is pressed).	<ul style="list-style-type: none"> • Turn off the machine, and then while holding down  and , turn the machine back on. The text in the display, all format settings, and all text files stored in the memory are erased.

ERROR MESSAGE LIST

Error Message	Cause	Remedy
1 BAR CODE / LABEL	<ul style="list-style-type: none"> This message appears if a barcode has already been added to the label when you hold down  and press . 	<ul style="list-style-type: none"> Limit the number of barcodes in the text to one.
4 DIGIT MIN.!	<ul style="list-style-type: none"> This message appears when less than the minimum four digits are entered as barcode data. 	<ul style="list-style-type: none"> Enter a minimum of four digits before pressing .
4 LINE LIMIT!	<ul style="list-style-type: none"> This message appears if four lines already exist when you press . 	<ul style="list-style-type: none"> Limit the number of lines in the text to four.
BATTERIES WEAK!	<ul style="list-style-type: none"> This message appears when the installed alkaline batteries become weak. 	<ul style="list-style-type: none"> Replace the batteries or use the AC adapter.
BUFFER EMPTY!	<ul style="list-style-type: none"> This message appears if you hold down  and press , , or , but no text has been entered in the display. This message appears if you try to print, but no text has been entered. This message appears if you try to store a text file in the memory, but no text has been entered in the display. 	<ul style="list-style-type: none"> Enter some text before starting the function. Enter text before printing. Enter text before storing.

Error Message	Cause	Remedy
BUFFER FULL!	<ul style="list-style-type: none"> This message appears if you try to enter a character, symbol, barcode, return or space after 99 characters have already been entered. 	<ul style="list-style-type: none"> Delete some existing text so that more can be entered.
CAN'T HERE!	<ul style="list-style-type: none"> This message appears if a character, symbol, space or return is entered while the cursor is located below the right half of a barcode mark. This message appears if the cursor is at the end of the text when you hold down  and press . <i>Number</i> 	<ul style="list-style-type: none"> Move the cursor or delete the barcode before entering the character, symbol or return. Move the cursor below a number before holding down  and pressing . <i>Number</i>
CHANGE ADAPTER	<ul style="list-style-type: none"> This message appears if a high-voltage adapter is being used. 	<ul style="list-style-type: none"> Remove the high-voltage adapter and connect the AC adapter (AD-60).
INPUT WHOLE CODE!	<ul style="list-style-type: none"> This message appears if the set number of digits are not entered in the barcode data. 	<ul style="list-style-type: none"> Input the correct number of digits.
INVAL. CHARS!	<ul style="list-style-type: none"> This message appears if the cursor is below a character other than a number or below a return mark () when you hold down  and press . <i>Number</i> 	<ul style="list-style-type: none"> Move the cursor below a number before holding down  and pressing . <i>Number</i>
LENGTH LIMIT!	<ul style="list-style-type: none"> This message appears if the length function is used to set a label length that is less than 1.6" (4.0 cm) or more than 11.8" (30.0 cm). 	<ul style="list-style-type: none"> Set the label length between 1.6" (4.0 cm) and 11.8" (30.0 cm).

Error Message	Cause	Remedy
LINE LIMIT!	<ul style="list-style-type: none"> This message appears if the number of lines in the text is greater than the maximum number of lines possible for the installed tape. 	<ul style="list-style-type: none"> Reduce the number of lines or install a tape of greater width.
MEMORY FULL!	<ul style="list-style-type: none"> This message appears if you try to store a text file after 300 characters have already been stored in the memory. 	<ul style="list-style-type: none"> Delete an unwanted file to make room for the new one.
NEED A, B, C, D START&END	<ul style="list-style-type: none"> This message appears if a letter between A and D has not been entered at the beginning and end of the barcode data when the CODABAR protocol is used. 	<ul style="list-style-type: none"> Enter a letter between A and D at the beginning and end of the barcode data.
NO FILES!	<ul style="list-style-type: none"> This message appears if you try to recall or delete a text file from the memory when none are stored. 	<ul style="list-style-type: none"> Store a text file first.
NO TAPE!	<ul style="list-style-type: none"> This message appears if you try to print a label or feed the tape when a tape cassette is not installed. 	<ul style="list-style-type: none"> Install a tape cassette and try again.
NUMBER TOO SMALL!	<ul style="list-style-type: none"> This message appears if the last number set to be printed is less than the selected number in the text when using the numbering function. 	<ul style="list-style-type: none"> Press the key of a number that is greater than the number in the text.
REPLACE BATTERIES!	<ul style="list-style-type: none"> This message appears if the installed alkaline batteries are about to run out. 	<ul style="list-style-type: none"> Replace the batteries or use the AC adapter.

Error Message	Cause	Remedy
ROM PROBLEM!	<ul style="list-style-type: none"> This message appears if there is a problem with the machine's read only memory. 	<ul style="list-style-type: none"> Contact your service representative.
SYSTEM ERROR!	<ul style="list-style-type: none"> This message appears if there is a problem with the machine's software. 	<ul style="list-style-type: none"> Contact your service representative.
TEXT TOO HIGH!	<ul style="list-style-type: none"> This message appears if the size of the text is larger than the width of the installed tape. 	<ul style="list-style-type: none"> Reduce the size of the characters or install a wider tape.
TEXT TOO LONG!	<ul style="list-style-type: none"> This message appears if the length of the text is longer than the label length that has been set using the length function. 	<ul style="list-style-type: none"> Delete some of the text, reduce the character width or increase the set label length.

SPECIFICATIONS

HARDWARE

- Input device:** Keyboard with 52 keys (including the power key)
- LCD:** 12 characters × 2 lines (7 × 5 dots/character)
17 indicators
- Print tape:** TZ tape
Four widths available:
1/4" (6 mm)
3/8" (9 mm)
1/2" (12 mm)
3/4" (18 mm)
- Power supply:** Six AA (AM3, LR6) alkaline batteries or optional AC adapter (AD-60)
Auto power-off if no key is pressed for 5 minutes
- Print head:** 128 dot/180 dpi
- Dimensions:** 4 3/4" (121 mm)(W) × 7 31/64" (190 mm)(D) × 2 51/64" (71 mm)(H)
- Weight:** 1.1 lbs. (520 g) (without a tape cassette and batteries installed)

SOFTWARE

- Buffer size:** Maximum 99 characters
Maximum four lines
- Memory size:** 300 characters
- Character size:** Five sizes (9, 12, 18, 24 and 36 points) + AUTO
All are available in normal and wide widths
- Print styles:** Normal, Bold, Outline, Shadow (each can be combined with Italic),
and Vertical

ACCESSORIES

● Supplies

Obtain tape cassettes and AC adapters from your nearest authorized dealer.

Use only Brother TZ tapes with this machine. **Brother cannot be held responsible for trouble caused by the use of unauthorized supplies.** Do not use tapes that do not have the  mark.

Stock No.	Description	QTY/ PACKAGE	PRICE
3/4" (18mm)-wide laminated tapes			
TZ-141	Black characters on clear adhesive	1	\$20.99
TZ-145	White characters on clear adhesive	1	\$20.99
TZ-241	Black characters on white adhesive	1	\$20.99
TZ-242	Red characters on white adhesive	1	\$20.99
TZ-243	Blue characters on white adhesive	1	\$20.99
TZ-344	Gold characters on black adhesive	1	\$24.99
TZ-345	White characters on black adhesive	1	\$23.99
TZ-441	Black characters on red adhesive	1	\$20.99
TZ-541	Black characters on blue adhesive	1	\$20.99
TZ-545	White characters on blue adhesive	1	\$23.99
TZ-641	Black characters on yellow adhesive	1	\$20.99
TZ-741	Black characters on green adhesive	1	\$20.99
TZ-B41	Black characters on fluorescent orange adhesive	1	\$24.99
TZ-M41	Black characters on clear (matte) adhesive	1	\$20.99
TZ-S241	Industrial (Strong adhesive) Black characters on white adhesive	1	\$21.99
TZ-WB41	Black characters on Bugs Bunny adhesive	1	\$23.99
TZ-WT41	Black characters on Taz adhesive	1	\$23.99
TZ-WS41	Black characters on Tweety & Sylvester adhesive	1	\$23.99
1/2" (12mm)-wide laminated tapes			
TZ-131	Black characters on clear adhesive	1	\$16.99
TZ-231	Black characters on white adhesive	1	\$17.99
TZ-232	Red characters on white adhesive	1	\$17.99
TZ-335	White characters on black adhesive	1	\$20.99
TZ-S231	Industrial (Strong adhesive) Black characters on white adhesive	1	\$18.99

Stock No.	Description	QTY/ PACKAGE	PRICE
3/8" (9mm)-wide laminated tapes			
TZ-121	Black characters on clear adhesive	1	\$14.99
TZ-221	Black characters on white adhesive	1	\$16.99
TZ-325	White characters on black adhesive	1	\$18.99
TZ-421	Black characters on red adhesive	1	\$16.99
TZ-S221	Industrial (Strong adhesive) Black characters on white adhesive	1	\$17.99
1/4" (6mm)-wide laminated tapes			
TZ-111	Black characters on clear adhesive	1	\$12.99
TZ-211	Black characters on white adhesive	1	\$14.99
TZ-315	White characters on black adhesive	1	\$17.99
TZ-S211	Industrial (Strong adhesive) Black characters on white adhesive	1	\$15.99

Special tapes

Stock No.	Description	QTY/ PACKAGE	PRICE
TZ-SE4	Black characters on 3/4" (18 mm) security tape	1	\$29.99
TZ-FA3	Blue characters on 1/2" (12 mm) fabric adhesive	1	\$24.99

Stamp kit

Stock No.	Description	QTY/ PACKAGE	PRICE
SK-MB	Stamp-making kit for Medium stamp with black ink	1	\$37.99
SH-MB	Additional stamper for Medium stamp with black ink	1	\$24.99

Options

Stock No.	Description	QTY/ PACKAGE	PRICE
TZ-CL4	Print head Cleaning Cassette	1	\$20.99
AD-60	AC adapter	1	\$24.99

BROTHER CONTACT INFORMATION

Service Center Locations

If you need a local service center, please call 1-800-284-HELP (4357) to locate the authorized service center closest to you.

Note: Be sure to call the Service Center before your visit.

Service centers do not provide operational assistance. See "Operational Assistance".

Operational Assistance

For technical and operational assistance you may call Brother Customer Service at: Voice 1-877-4-PTouch, or Fax 1-901-379-1210

Assistance on the Internet

For product information and downloading the latest drivers: <http://www.brother.com>

For purchasing accessories and certain Brother products: <http://www.brothermall.com>

Accessories and Supplies

To order Brother accessories or supplies by Visa, MasterCard, Discover or American Express you may call toll free 1-888-879-3232, or complete the order form in your user's guide and

fax both sides of the form to 1-800-947-1445

For purchasing accessories on the Internet: <http://www.brothermall.com>

To order by mail or pay by check, Please complete the accessory order form and mail it along

with payment to:

Brother International Corporation
Attn: Consumer Accessory Division
P.O. Box 341332
Bartlett, TN 38184-1332

Fax-Back System

Brother Customer Service has installed an easy to use Fax-Back System so you can get instant answers to common technical questions and product information for all Brother products.

This system is available 24 hours a day, 7 days a week. You can use the system to send the

information to any fax machine, not just the one you are calling from.

Please call 1-800-521-2846 and follow the voice prompts to receive faxed instructions on

how to use the system and an index of Fax-Back subjects.

P-TOUCH ACCESSORY ORDER FORM

Dear Customer:

This order form is provided for your convenience should your retailer not stock the item(s) needed. To order by mail, send this completed form along with proper payment to the address below OR credit card holders: Call toll-free 1-888-879-3232, fax completed order form to 1-800-947-1445, or visit our web site at <http://www.brothermall.com>. Please refer to the Accessories listing in your User's Guide for stock no. and price.

Stock No.	Description	Price	Quantity	Total
Subtotal				

Name: _____ **Accessory Subtotal:** \$ _____

Address: _____ AZ, CA, CO, CT, FL, GA, IL, LA, MA,
 MD, MI, MN, MO, NC, NJ, NV, NY,
 City: _____ OH, PA, TN, TX, VA, WA residents
 State/Zip: _____ add applicable sales tax \$ _____

Daytime Phone: _____

Shipping/Handing Options
 Please choose one:

- Standard (\$5.00)
- 2nd day air freight (\$8.75) Mandatory for all deliveries outside of the continental U.S. (Alaska, Hawaii, Puerto Rico, Virgin Islands & Canada)
- All other overseas orders (\$25.00) \$ _____

TOTAL DUE (US dollars) \$ _____

SEND ORDER FORM TO:
 Brother International Corp.
 Attn: Consumer Accessory Div.
 P.O. Box 341332
 Bartlett, TN38184-1332

Method of payment (Check one)

Visa MasterCard Discover American Express Check/Money Order

Account Number _____

Expiration Date _____

Signature _____

* Prices subject to change without notice.

P-TOUCH ACCESSORY ORDER FORM

Dear Customer:

This order form is provided for your convenience should your retailer not stock the item(s) needed. To order by mail, send this completed form along with proper payment to the address below OR credit card holders: Call toll-free 1-888-879-3232, fax completed order form to 1-800-947-1445, or visit our web site at <http://www.brothermall.com>. Please refer to the Accessories listing in your User's Guide for stock no. and price.

Stock No.	Description	Price	Quantity	Total
Subtotal				

Name: _____ **Accessory Subtotal:** \$ _____

Address: _____ AZ, CA, CO, CT, FL, GA, IL, LA, MA,
 City: _____ MD, MI, MN, MO, NC, NJ, NV, NY,
 State/Zip: _____ OH, PA, TN, TX, VA, WA residents
 Daytime Phone: _____ add applicable sales tax \$ _____

Shipping/Handing Options

Please choose one:

- Standard (\$5.00)
- 2nd day air freight (\$8.75) Mandatory for all deliveries outside of the continental U.S. (Alaska, Hawaii, Puerto Rico, Virgin Islands & Canada)
- All other overseas orders (\$25.00) \$ _____

TOTAL DUE (US dollars) \$ _____

SEND ORDER FORM TO:

Brother International Corp.
 Attn: Consumer Accessory Div.
 P.O. Box 341332
 Bartlett, TN38184-1332

Method of payment (Check one)

Visa MasterCard Discover American Express Check/Money Order

Account Number _____

Expiration Date _____

Signature _____

* Prices subject to change without notice.

***GUIA DE
INSTRUCCIONES***

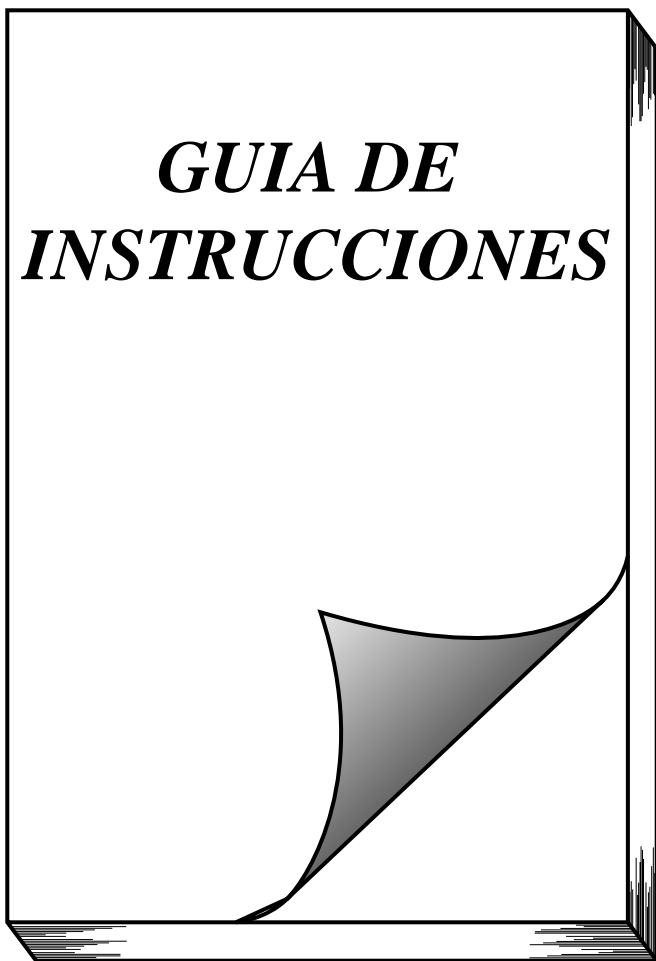

INTRODUCCIÓN

¡Muchas gracias por la adquisición de esta P-touch!

Su nueva P-touch le permitirá crear etiquetas y sellos para cualquier aplicación. Su versatilidad le permitirá diseñar etiquetas personales eligiendo entre gran variedad de diseños de marcos y entre muchos tamaños y estilos de caracteres. Además, las cuatro diferentes anchuras de cinta (1/4" (6 mm), 3/8" (9 mm), 1/2" (12 mm) y 3/4" (18 mm)) y la gran variedad de colores de cinta, le permitirán imprimir etiquetas personalizadas, muy útiles para relleno en código de colores.

Usted ya no tendrá que preocuparse por tareas urgentes que requieren impresión profesional. La calidad y el rendimiento de la P-touch 1300 es una máquina extremadamente práctica.

Aunque esta máquina es fácil de utilizar, le sugerimos que lea cuidadosamente la Guía del usuario antes de comenzar, y que la guarde a mano para futuras referencias.

Utilice sólo el adaptador de CA diseñado exclusivamente para esta máquina. Consulte *PRECAUCIONES GENERALES* de la página 1.

Después de haber utilizado la P-touch, guárdela en su maletín de transporte. Este maletín de transporte ha sido diseñado para ayudarle a proteger la P-touch y para poder llevarla consigo a cualquier parte.

AVISO DE LA FCC

Este equipo ha sido probado y cumple con los límites de un aparato digital de la Clase B, siguiendo el apartado 15 de las normas de la FCC. Estos límites están pensados para proporcionar una protección razonable contra interferencias nocivas dentro de una instalación residencial. Este equipo podría interferir de forma nociva con comunicaciones por radio si no se instala y utiliza siguiendo las instrucciones. No obstante, no existe ninguna garantía de que no vayan a suceder interferencias en una instalación concreta. Si este equipo causara interferencias nocivas con la recepción de radio o televisión, lo cual puede determinarse poniendo el equipo en ON u OFF, se recomienda que el usuario intente corregir dichas interferencias mediante una de las siguientes medidas:

- Reoriente o ponga la antena receptora en otro lugar.
- Aumente la separación entre el equipo y el receptor.
- Conecte el equipo en una toma de un circuito diferente de la que esté conectada el receptor.
- Consulte a su distribuidor o a un técnico experimentado de radio/televisión.
- Los cambios o modificaciones no expresamente aprobados por Brother Industries, Ltd. pueden anular el derecho de utilización del equipo.

A continuación se indican los números de patente y de publicación de patente relacionados con este producto:

USP4839742	USP4983058	USP5120147
USP4927278	USP5009530	
USP4976558	USP5069557	

ÍNDICE

PRECAUCIONES GENERALES	1
PILAS	2
ADAPTADOR DE CA OPCIONAL	3
CASETES DE CINTA	4
COLOCACIÓN DE ETIQUETAS	5
CABEZAL DE IMPRESIÓN Y RODILLOS	7
CORTADOR DE LA CINTA	9
MALETÍN DE TRANSPORTE	10
TECLAS CODE Y CAPS	11
TECLA DEL CURSOR	12
TECLA DE RETORNO	14
TECLA DE BORRADO (DEL)	16
FUNCIÓN DE REPOSICIÓN (CLEAR)	17
FUNCIÓN DE ACENTOS	18
FUNCIÓN DE SÍMBOLOS	19
FUNCIÓN DE LONGITUD	20
FUNCIONES DE TAMAÑO Y DE ANCHURA	21
FUNCIÓN DE ESTILO	23
FUNCIÓN DE SUBRAYADO	25
FUNCIÓN DE MARCOS	26
FUNCIÓN DE MÁRGENES DE LA CINTA	27
FUNCIÓN DE LA ALINEACIÓN HORIZONTAL	29
FUNCIÓN DE IMPRESIÓN DE ESPEJO	30
FUNCIÓN DE CÓDIGO DE BARRAS	31
TECLA PRINT Y FUNCIÓN DE AVANCE DE LA CINTA	36
FUNCIÓN DE NUMERACIÓN	37
FUNCIÓN DE IMPRESIÓN REPETIDA	38
FUNCIONES DE LA MEMORIA	39
SOLUCIÓN DE PROBLEMAS	42
LISTA DE MENSAJES DE ERROR	43
ESPECIFICACIONES	47
ACCESORIOS	48

PRECAUCIONES GENERALES

⚠ ADVERTENCIA: Tenga EN cuenta las advertencias siguientes para evitar dañar la P-touch o sus accesorios.

- Con esta máquina utilice solamente cintas TZ Brother. No use cintas que no posean la marca **TZ** TAPE.
- Utilice sólo el adaptador de CA diseñado exclusivamente para esta máquina. La utilización de cualquier otro adaptador de CA podría anular la garantía.
- No introduzca ningún objeto extraño en el interior de la máquina.
- No utilice la máquina en lugares polvorientos, y manténgala alejada de la luz solar directa y de la lluvia.
- No exponga la máquina a altas temperaturas ni a gran humedad. No la deje nunca sobre el tablero de instrumentos ni en la parte posterior de su automóvil.
- No coloque nada de goma o de plástico sobre la máquina durante mucho tiempo. Si lo hiciese, podrían producirse manchas.
- No limpie la máquina con alcohol ni otros disolventes orgánicos. Utilice solamente un paño suave y seco.
- No toque el mecanismo del cabezal de impresión. Si toca el cabezal, límpielo inmediatamente con un palillo de punta de algodón para evitar que se dañe permanentemente.
- No tire de la cinta alimentada desde la P-touch. Esto podría dañar el casete de cinta.
- Cuando no vaya a utilizar la máquina durante mucho tiempo, y no sea necesario conservar los archivos de texto en la memoria, desenchufe el adaptador de CA, y extráigale las pilas para evitar los daños que podría causar la fuga de su electrólito.

⚠ PRECAUCIÓN: Tenga en cuenta las precauciones siguientes a fin de evitar el mal funcionamiento de la P-touch.

- Cuando el adaptador de CA (AD-60) esté conectado, si lo desenchufa del tomacorriente de la red antes de desenchufarlo de la máquina es posible que se borren todos los archivos de texto de la memoria, incluso aunque tenga las pilas instaladas.
- Para esta máquina, utilice seis pilas alcalinas AA (AM3, LR6).

PILAS

Esta máquina ligera y portátil puede utilizarse en cualquier lugar instalando seis (6) **pilas alcalinas AA (AM3, LR6)**. Cuando cambie las pilas, reemplace siempre las seis pilas al mismo tiempo.

Para cambiar las pilas:

- 1 Extraiga la cubierta posterior presionando la zona áspera del extremo superior de la máquina y tirando de la cubierta hacia fuera. Al extraer la cubierta posterior se levantará la palanca de liberación de la cinta.
- 2 Si las pilas están instaladas, extráigaslas.
- 3 Inserte seis pilas nuevas, cerciorándose de que queden encaradas en el sentido indicado en la ilustración de la parte inferior del compartimiento de las mismas. Los extremos positivos de las tres pilas de la fila inferior deberán quedar apuntando hacia la parte inferior de la máquina, mientras que los polos positivos de las pilas de las tres pilas superiores deberán quedar apuntando en sentido opuesto.
- 4 Fije la cubierta posterior insertando la lengüeta del extremo inferior de la cubierta en la ranura del extremo inferior de la máquina, y después empujando firmemente hacia abajo el extremo superior de la cubierta hasta que chasquee en su lugar.

☞ *Cerciórese de insertar las pilas nuevas antes de cinco minutos de haber extraído las viejas, ya que de lo contrario el texto mostrado en la pantalla de cristal líquido y los archivos de texto almacenados en la memoria se perderían (a menos que la máquina esté enchufada en un tomacorriente de la red con el adaptador de CA).*

Extraiga las pilas y desconecte el adaptador de CA si no se propone utilizar la máquina durante períodos de tiempo prolongados. Cuando se desconecta la alimentación, se pierden el texto que se muestra en la pantalla y el que está almacenado en la memoria.

Si no se emplean pilas alcalinas, no podrán imprimirse tipos de caracteres grandes.

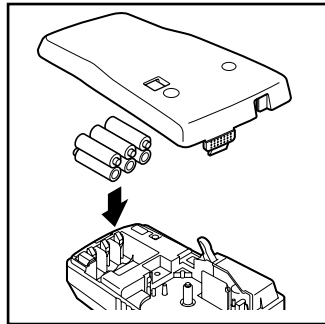
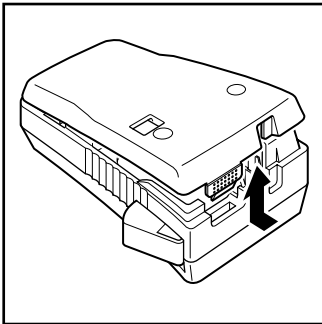

ADAPTADOR DE CA OPCIONAL

El adaptador de CA (modelo AD-60) le permite emplear esta máquina siempre que disponga de una toma de corriente eléctrica.

Para conectar el adaptador de CA opcional:

- 1 Enchufe la clavija del cable del adaptador de CA en la toma marcada con DC IN 9,5V del extremo posterior de la máquina.
- 2 Inserte la clavija del adaptador de CA en la toma de corriente más cercana.

☞ *Emplee sólo el adaptador de CA diseñado exclusivamente para esta máquina.*

Extraiga las pilas y desconecte el adaptador de CA si no se propone utilizar la máquina durante períodos de tiempo prolongados. Cuando se desconecta la alimentación, se pierden el texto que se muestra en la pantalla y el que está almacenado en la memoria.



Cuando el adaptador de CA (AD-60) esté conectado, si lo desenchufa del toma-corriente de la red antes de desenchufarlo de la máquina es posible que se borren todos los archivos de texto de la memoria, incluso aunque tenga las pilas instaladas.

Se recomienda emplear el adaptador de CA para imprimir tipos de caracteres grandes y códigos de barras con cintas de 3/4" (18 mm) porque esta operación pueden gastar las pilas con rapidez.

CASETES DE CINTA

Un casete de TZ se suministra con la unidad. Sin embargo, para esta máquina hay disponibles una amplia gama de casetes de cinta TZ de distintos colores y tamaños, es posible crear etiquetas diferentes codificadas por colores o tamaños.

Para cambiar el casete de cinta TZ:

- 1 Extraiga la cubierta posterior presionando la zona áspera del extremo superior de la máquina y tirando de la cubierta hacia fuera. Al extraer la cubierta posterior se levantará la palanca de liberación de la cinta.
- 2 Si hay un casete de cinta instalado, extráigalo tirando de él directamente hacia arriba.
- 3 Si la cinta entintadora del otro casete de cinta está floja, utilice un dedo para bobinar la rueda dentada en el sentido de la flecha del casete hasta que la cinta quede tensa.
☞ Si está utilizando un casete de cinta nuevo provisto de retén, cerciórese de extraerlo antes de instalar el casete. Cerciórese de que el extremo de la cinta pase por debajo de las guías de la cinta del casete.
- 4 Inserte firmemente el casete de cinta en el compartimiento del mismo, cerciorándose de que toda la parte posterior del casete quede en contacto con la parte inferior del compartimiento.
☞ Cuando inserte el casete de cinta, cerciórese de que la cinta interior no quede enganchada en la esquina de la guía metálica.
- 5 Fije la cubierta posterior insertando la lengüeta del extremo inferior de la cubierta en la ranura del extremo inferior de la máquina, y después empujando firmemente hacia abajo el extremo superior de la cubierta hasta que chasquee en su lugar.
- 6 Si la alimentación de la máquina está desconectada, conéctela, y después haga avanzar la cinta para tensarla manteniendo pulsada  y presionando  una vez.
- 7 Presione la palanca del cortador de la cinta para cortar el exceso de cinta.

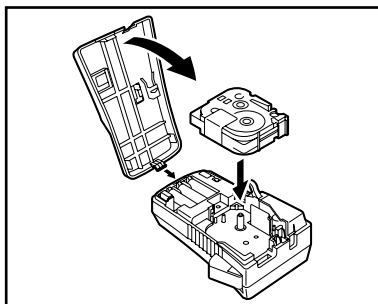
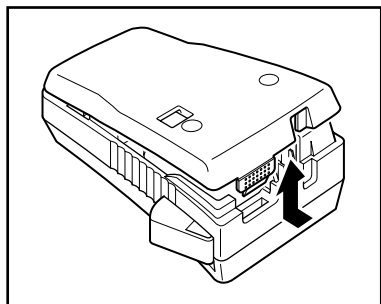

COLOCACIÓN DE ETIQUETAS

Cinta industrial (superadhesiva)

En comparación con la cinta laminada convencional, la cinta industrial posee más resistencia adhesiva, proporcionando mayor adhesión a superficies difíciles. Debido a esta adhesión mejorada, cuando utilice esta cinta, tendrá que tener en cuenta las precauciones siguientes.

- No adhiera esta cinta a la piel.
- Dependiendo de las condiciones ambientales, la ubicación y la calidad del material al que adhiera esta cinta, ésta puede descolorarse o es posible que no pueda despegarse completamente, dañando posiblemente la superficie en la que fue adherida.
- Antes de adherir esta cinta pruébela fijando un trozo pequeño en una parte sin importancia de la superficie deseada.
- Si el material adhesivo acumulado en el cortador dificulta el corte de la cinta, límpielo como se explica en la página 9.

CINTA LAMINADA

La varilla suministrada permite que, en las cintas laminadas, usted pueda extraer fácilmente el papel del dorso de la etiqueta.

- 1 Tome la cinta con la mano izquierda, con la superficie impresa arriba, y tome la varilla con la mano derecha.
- 2 Pase la mitad de la cinta por el orificio estrecho largo de la varilla.
- 3 Gire tres cuartos de vuelta la varilla hacia usted y separe la varilla de usted como se muestra abajo.
- 4 Pele el papel del dorso de la etiqueta.

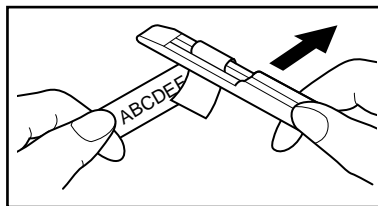
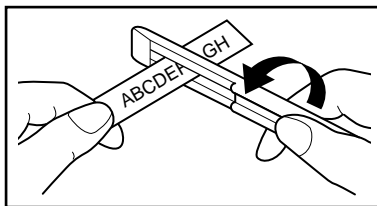

CINTAS DE TELA

La cinta de tela se emplea para adherir un trozo de tela impresa con el texto en prenda de vestir empleando una plancha. Después de imprimir el texto en la cinta de tela y de haber cortado la etiqueta empleando unas tijeras, coloque la etiqueta sobre una prenda planchada en la posición en la que desee ponerla de modo que el texto impreso pueda leerse correctamente. Cubra la etiqueta con otra tela y emplee un ajuste de la plancha de temperatura medio-alta (320 a 356°F (160 a 180 °C)) para presionar con firmeza durante 10 a 15 segundos. Para más detalles, consulte las instrucciones suministradas con el casete de cinta de tela.

☞ *La etiqueta tendrá un fondo blanco sobre tela de color.*

CINTA DE SELLOS

Haciendo un cliché con una película de cliché para sellos TZ y fijándola al portapelícula de estampado autoentintador, podrá crear fácilmente sus propios sellos personalizados. Para crear un sello utilizando su P-touch 1300, instale un casete de película de cliché para sellos MEDIUM de 3/4" (18 mm) de anchura de con un área de impresión ancha de 1/2" (12 mm), como se describe en la página 4, y después introduzca el texto como se explica a continuación.

- 1 Utilice la función **Longitud** para ajustar la longitud de la cinta a 4,1" (10,5 cm).
- 2 Utilice la función **Alineación horizontal** para seleccionar el ajuste **CENTER**.
- 3 Utilice la función **Margen de la cinta** para seleccionar el ajuste **FULL**.
- 4 Introduzca el texto de forma que encaje dentro del área de 3/8" x 2,2" (9 x 55 mm).

Para comprobar el texto y su longitud, extraiga el casete de película de cliché para sellos, inserte un casete de cinta para etiquetas de 1/2" (12 mm) de anchura, y después imprima una etiqueta de prueba.

Para más información consulte las instrucciones suministradas con el juego de estampado.

☞ *Se recomienda que utilice el adaptador de CA (AD-60) para imprimir sellos, porque estas operaciones consumen rápidamente las pilas. Con las pilas débiles, los sellos no se imprimirán correctamente.*

CABEZAL DE IMPRESIÓN Y RODILLOS

De vez en cuando, motas de polvo o suciedad se adhieren al cabezal de impresión y a los rodillos de la máquina. Suele suceder cuando se emplea la unidad en exteriores o en lugares con mucho polvo. Si alguna parte del cabezal de impresión está cubierta de polvo, es posible que aparezca una franja horizontal blanca por el texto de la etiqueta.

Por lo tanto, al igual que con las grabadoras de cintas, el cabezal de la máquina deberá limpiarse de vez en cuando.

Para limpiar el cabezal de impresión y los rodillos:

- ❶ Desconecte la alimentación de la máquina.
- ❷ Quite la cubierta posterior y después extraiga el casete, si está instalado. El cabezal de impresión y los rodillos se encuentran en el compartimiento de la cinta.
- ❸ Cabezal de impresión: Emplee un palillo con punta de algodón seco para frotar con cuidado el cabezal de impresión con movimiento hacia arriba y abajo.
Rodillos: Emplee un palillo con punta de algodón seco para frotar cada rodillo con movimiento hacia arriba y abajo mientras los gira con el dedo.
- ❹ Instale un casete, fije la cubierta posterior, y después pruebe de nuevo la impresión.
- ❺ Repita el paso ❷ y ❹ empleando un palillo con cabeza de algodón humedecido en alcohol isopropílico (limpieza).

Si no funciona nada de lo de arriba, póngase en contacto con el representante de servicio.

☞ *El cabezal de impresión podrá limpiarse más fácilmente con el casete limpiador del cabezal de impresión opcional TZ-CL4 (3/4" (18 mm)).*

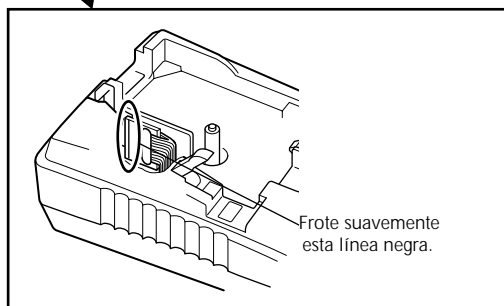
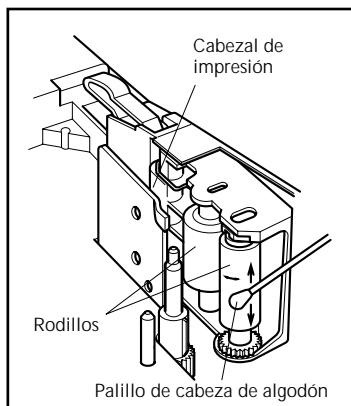
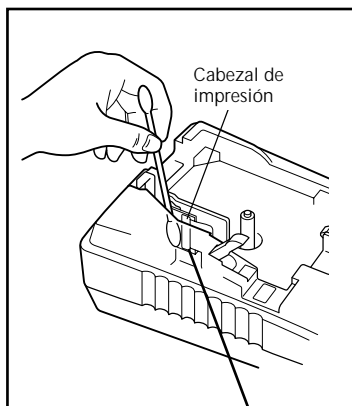

CORTADOR DE LA CINTA

Cuando utilice el cortador de la cinta, éste puede cubrirse con sustancia adhesiva, dificultando el corte de la cinta. Si la cinta no puede cortarse correctamente, limpie las cuchillas del cortador de la cinta como se explica a continuación.

☞ *Para evitar lesiones, tenga mucho cuidado de no tocar las cuchillas del cortador con las manos desnudas.*

Para limpiar las cuchillas del cortador de la cinta:

- 1 Desconecte la alimentación de la máquina.
- 2 Quite la cubierta posterior y después extraiga el casete, si está instalado. El cortador de la cinta se encuentra cerca de la ranura de salida de la cinta.
- 3 Utilizando un palillo de punta algodón humedecido en alcohol isopropílico (para limpieza) o etanol, frote las cuchillas del cortador de la cinta con movimiento ascendente y descendente.

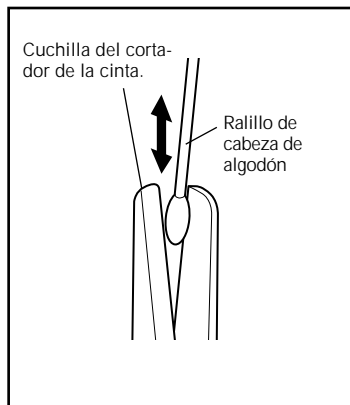
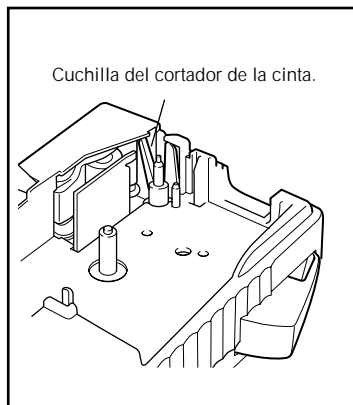

⚠ Tenga cuidado de no tocar las cuchillas del cortador con las manos desnudas.

MALETÍN DE TRANSPORTE

El maletín de transporte suministrado ha sido diseñado para proteger su P-touch y los accesorios cuando los guarde o lleve consigo. Por lo tanto, guárdelos en el maletín cuando no vaya a utilizarlos.

Antes de abrir el maletín de transporte, cerciórese de que el logotipo "brother P-touch" esté encarado hacia arriba.

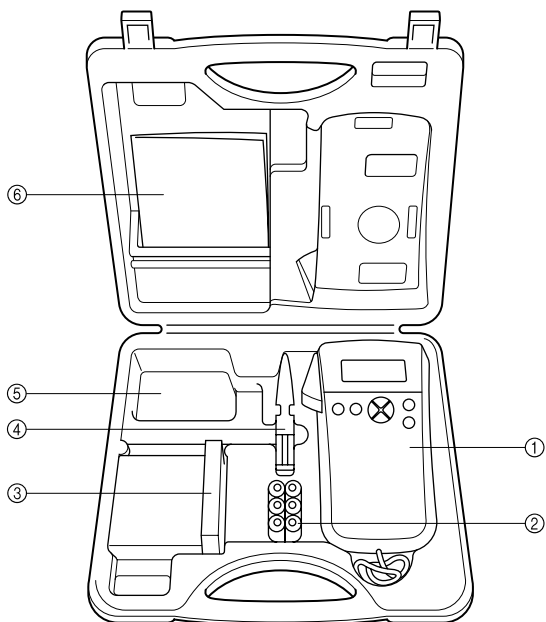

- ① P-touch Model PT-1300
- ② Seis pilas AA
- ③ Casetes de cinta

☞ Coloque los casetes de cinta de forma que el extremo con la etiqueta fijada quede encarada hacia arriba.

Este compartimiento puede alojar hasta cinco casetes de cinta de 1/4" (6 mm), 3/8" (9 mm) o 1/2" (12 mm) de anchura, cuatro de 3/4" (18 mm) de anchura, o una combinación de tres casetes de cinta de 1/2" (12 mm) y dos de 3/4" (18 mm) de anchura.

- ④ Separador de la cinta
- ⑤ Adaptador de CA (AD-60)

☞ Este compartimiento puede alojar un adaptador de CA opcional diseñado exclusivamente para el PT-1300.

- ⑥ Guía del usuario

TECLAS CODE Y CAPS

La mayoría de los caracteres podrán introducirse presionando simplemente sus teclas. Sin embargo, para utilizar funciones especiales o para introducir mayúsculas, caracteres acentuados, y ciertos símbolos, tendrá que utilizar las teclas especiales siguientes.



TECLA CODE

Para utilizar una función o escribir caracteres impresos sobre o debajo de una tecla:





- Mantenga pulsada  y presione la tecla situada inmediatamente sobre o debajo de la función deseada o del carácter impreso en naranja.

TECLA CAPS

Para escribir continuamente letras mayúsculas:

- 1 Presione  hasta que se encienda el indicador **Caps** () situado en la parte izquierda del visualizador.
- 2 Presione las teclas correspondientes a las letras deseadas.
*☞ Para salir del modo **Caps**, presione  hasta que se apague el indicador **Caps**.*

TECLA DEL CURSOR

El visualizador de LCD de esta máquina muestra dos filas de 11 caracteres; sin embargo, el texto que usted cree puede tener hasta 99 caracteres de longitud. Podrá revisar y editar el texto empleando las teclas del cursor (, , , ) para moverlo y que muestre las distintas partes en el visualizador.

TECLA DEL CURSOR IZQUIERDA



Para mover el cursor un carácter hacia la izquierda:

- Presione  una vez.

Para mover el cursor varios caracteres hacia la izquierda:

- Mantenga presionado  hasta que el cursor se mueva a la posición deseada.

Para mover el cursor al principio de la línea actual:

- Mantenga presionado  y presione .

TECLA DEL CURSOR DERECHA



Para mover el cursor un carácter hacia la derecha:

- Presione  una vez.

Para mover el cursor varios caracteres hacia la derecha:

- Mantenga presionado  hasta que el cursor se mueva a la posición deseada.

Para mover el cursor al final de la línea actual:

- Mantenga presionado  y presione .

TECLA DEL CURSOR HACIA ARRIBA



Para mover el cursor a la línea anterior:

- Presione  una vez.

Para mover el cursor varias líneas hacia arriba:

- Mantenga presionado  hasta que el cursor se mueva a la posición deseada.

Para mover el cursor al principio de todo el texto:

- Mantenga presionado  y presione .

TECLA DEL CURSOR HACIA ABAJO



Para mover el cursor a la línea siguiente:

- Presione  una vez.



Para mover el cursor varias líneas hacia abajo:

- Mantenga presionado  hasta que el cursor se mueva a la posición deseada.

Para mover el cursor al final de todo el texto:

- Mantenga presionado  y presione .

TECLA DE RETORNO

Al igual que con una máquina de escribir o con un procesador de texto, la tecla de retorno de esta máquina () se utiliza para finalizar una línea de texto e iniciar otra. Cuando haya finalizado la introducción de una línea de texto, presione la tecla de retorno a fin de añadir una marca de retorno () al final de la línea e iniciar una nueva línea.

☞ *Usted podrá introducir un máximo de cuatro líneas de texto. Si presiona  cuando el cursor se encuentre en la cuarta línea, aparecerá el mensaje "4 LINE LIMIT!".*

El número de líneas que podrán imprimirse en la cinta instalada dependerá de la anchura de la cinta.





Anchuras de cinta	Número máximo de líneas que pueden imprimirse
1/4" (6 mm)	1
3/8" (9 mm)	2
1/2" (12 mm)	2
3/4" (18 mm)	4

La tecla de retorno también podrá utilizarse para seleccionar un ítem de una lista (p. ej., añadir un símbolo o un carácter acentuado al texto) o para aplicar un ajuste seleccionado.

Es posible que aparezcan en el visualizador de LCD algunas preguntas para que confirme un comando, especialmente cuando la función que usted ha seleccionado es para borrar o afectar archivos. En estos casos, si presiona  es como si respondiera "sí".

☞ *Para contestar "no", presione . Consulte la descripción de la TECLA DE BORRADO (DEL) de la página 16.*



Para añadir una nueva línea

- 1 Presione , ,  o  para colocar el cursor a la derecha del carácter con el que finaliza la línea.
- 2 Presione . Al final de la línea aparecerá la marca de retorno (↵) y el cursor se moverá hasta la línea nueva.

Para aplicar los elementos seleccionados:

- Presione una vez .

TECLA DE BORRADO (DEL)

La tecla de retroceso () le permitirá eliminar caracteres hacia la izquierda de la posición actual del cursor. Se diferencia de la tecla de flecha hacia la izquierda del cursor () en el sentido de que ésta solamente mueve el cursor sin borrar caracteres.

La tecla de retroceso también podrá utilizarse para abandonar la mayoría de las funciones y volver a la visualización anterior sin cambiar el texto.





☞ *La tecla de retroceso no podrá utilizarse para abandonar la función **Código de barras**. Para abandonar esta función, mantenga pulsada  y presione*







Es posible que aparezcan en el visualizador de LCD algunas preguntas para que confirme un comando, especialmente cuando la función que usted ha seleccionado es para borrar o afectar archivos. En estos casos, si presiona  es como si respondiera "sí".

☞ *Para contestar "no", presione . Consulte la descripción de la TECLA DE RETORNO de la página 14.*

Para borrar un carácter:

- 1 Presione , ,  o  para situar el cursor debajo del carácter que está inmediatamente a la derecha del carácter que usted desea borrar.
- 2 Presione  una vez.

Para borrar una secuencia de caracteres:

- 1 Presione , ,  o  para situar el cursor debajo del carácter que está inmediatamente a la derecha del último carácter que usted desea borrar.
- 2 Mantenga presionado  hasta que se hayan borrado todos los caracteres que usted deseaba borrar.



Para abandonar una función sin cambiar el texto:

- Presione  para volver a su texto.

FUNCIÓN DE REPOSICIÓN (CLEAR)

La función **Reposición** se utiliza para eliminar todos los caracteres del visualizador a fin de poder comenzar a introducir nuevo texto. Aunque se borrará todo el texto, el modo **Caps** y los ajustes de formato de caracteres (**Tamaño, Ancho, Estilo, Subrayado, y Marco**) no cambiarán.

Para borrar todo el texto:

- Mantenga pulsada  y presione . Todo el texto se borrará del visualizador.



FUNCIÓN DE ACENTOS

La función de **acentos** también podrá utilizarse para añadir caracteres acentuados al texto. Los caracteres acentuados se agrupan de acuerdo con la letra mayúscula o minúscula con la que se combinan. Hay disponibles los siguientes caracteres acentuados:

Letras	Caracteres acentuados	Letras	Caracteres acentuados
a	à á â ã ä å æ	l	ĺ ľ
A	À Á Â Ã Ä Å Æ	n	ñ
c	ç	N	Ñ
C	Ç	o	ó ô õ ö
e	è é ê ë	O	Ó Ô Õ Ö
E	È É Ê Ë	u	ù ú û ü
i	í î	U	Û Ü Û Ü



☞ Algunos de los caracteres acentuados podrán escribirse utilizando la función **Símbolo** (consulte las páginas 19).

Para escribir un carácter acentuado:





❶ Mantenga presionado  y presione . Aparecerá el mensaje "ACCENT a-u/A-U?" en el visualizador.

❷ Presione la tecla de la letra acentuada deseada.

☞ Si desea escribir una letra mayúscula, presione  para entrar en el modo **Caps** (el indicador **Caps** se encenderá) antes de presionar la tecla correspondiente a la letra.

❸ Presione  o  hasta que parpadee el carácter acentuado.

❹ Presione . La letra acentuada se añadirá al texto.

☞ Para escribir una secuencia de caracteres acentuados, mantenga presionada  antes de pulsar . Después continúe añadiendo caracteres acentuados seleccionándolos como se ha explicado en los pasos ❷ y ❸, manteniendo pulsada  y presionando . Después de haber seleccionado el último carácter de la serie, presione simplemente .

FUNCIÓN DE SÍMBOLOS

Además de letras, de los símbolos y los números de las teclas, hay 46 marcas adicionales con la función de **símbolos**. Los siguientes símbolos están disponibles.

Símbolos											
Ü	Æ	æ	Ã	ã	Ě	ě	Õ	õ	TM	®	©
+	×	÷	=	§	2	3	2	3	4	★	•

Para escribir un símbolo:

- 1 Presione ^{Feed} . Aparecerá una fila de símbolos en el visualizador.
- 2 Presione o para visualizar distintas filas de símbolos y presione o hasta que parpadee el símbolo deseado.
- 3 Presione ^{Memory} . El símbolo aparecerá en el texto.

☞ Para escribir una secuencia de símbolos, mantenga presionada antes de pulsar ^{Memory} . Después continúe añadiendo símbolos seleccionándolos como se ha explicado en los pasos 2 y 3, manteniendo pulsada y presionando ^{Memory} . Después de haber seleccionado el último símbolo de la serie, presione simplemente ^{Memory} .



FUNCIÓN DE LONGITUD



Aunque la longitud de la etiqueta impresa ajusta automáticamente dicha longitud de acuerdo con el texto introducido, es posible que usted desee hacer una etiqueta con una longitud específica. La función de **longitud** le permitirá ajustar la longitud de la etiqueta entre 1,6" y 11,8" (4,0 cm y 30,0 cm).

El ajuste de longitud predeterminado es **OFF**. Si selecciona **ON**, el indicador **Longitud** de la parte inferior del visualizador se encenderá.

☞ *Si desconecta y vuelve a conectar la alimentación de la máquina, el ajuste de longitud volverá a **OFF**.*

Para activar y desactivar la función de longitud:



① Manteniendo presionada , presione una vez , y mantenga presionada  hasta que se visualice brevemente la longitud actual de la etiqueta (texto y ambos márgenes), y después haga que se visualice el ajuste de longitud de etiqueta actual (**ON** u **OFF**).

② Manteniendo presionada , continúe presionando  hasta que se visualice el ajuste de longitud de etiqueta deseado.

☞ *Cuando seleccione **ON**, se encenderá el indicador de **longitud**.*

③ Suelte . Si había seleccionado **ON**, se visualizará la longitud actual de la etiqueta.

Para ajustar la longitud de la etiqueta:

④ Presione  o  para seleccionar la longitud deseada, o utilice las teclas numéricas para introducir la longitud.

☞ *Para cambiar la longitud en pasos de 1" (1,0 cm), mantenga pulsada *

o , y después presione la tecla cuando se visualice el ajuste deseado.

El ajuste predeterminado (3,9" (10,0 cm)) podrá seleccionarse pulsando

.

⑤ Presione .

FUNCIONES DE TAMAÑO Y DE ANCHURA

El tamaño de los caracteres puede ajustarse empleando las funciones de **tamaño** (Size) y de **ancho** (Wide). Puesto que el tamaño de los caracteres que puede utilizarse depende del ancho de la cinta, la tabla siguiente indica los tamaños de caracteres que pueden utilizarse con cada ancho de cinta.

Anchos de cinta	Tamaños (en puntos)
1/4" (6 mm)	12, 9
3/8" (9 mm)	18, 12, 9
1/2" (12 mm)	24, 18, 12, 9
3/4" (18 mm)	36, 24, 18, 12, 9

El ajuste predeterminado del tamaño es **AUTO** y el de la anchura es **OFF**. El ajuste de tamaño actualmente seleccionado se mostrará siempre mediante los indicadores de la parte superior del visualizador. Cuando seleccione el ajuste de anchura **ON**, se encenderá el indicador **Wide** de la esquina superior izquierda del visualizador.

Con el ajuste de tamaño **AUTO**, la máquina comparará su texto con la anchura de la cinta instalada y ajustará automáticamente los tamaños al tamaño más grande posible. Sin embargo, también están disponibles otros cinco tamaños de puntos, y cada uno de ellos podrá imprimirse en caracteres anchos.

☞ *Si selecciona el ajuste del tamaño **AUTO** y solamente ha introducido una línea de caracteres, el texto podrá imprimirse con un tamaño de caracteres ligeramente más grande que el máximo para la cinta instalada en cualquiera de las condiciones siguientes:*

- *Está instalada una cinta de 1/2" (12 mm) o de 3/4" (18 mm) de anchura y el texto solamente contiene letras mayúsculas.*
- *Está instalada una cinta de 3/4" (18 mm) y no se ha aplicado el ajuste de **Estilo, Subrayado, ni Marco**.*

Anchura de la cinta Líneas del texto	1/4" (6 mm)	3/8" (9 mm)	1/2" (12 mm)	3/4" (18 mm)
	1	12 pts	18 pts	Todas mayúsculas: 29 pts No todas mayúsculas: 24 pts
2	N/A	9 pts	12 pts	18 pts
3	N/A	N/A	N/A	12 pts
4	N/A	N/A	N/A	9 pts

Para cambiar el ajuste del tamaño:

- Manteniendo presionada **Code**, pulse una vez **Size 1**, y mantenga presionada **Code** para hacer que se visualice el tamaño actualmente ajustado.
- Siguiendo manteniendo presionada **Code**, continúe presionando **Size 1** hasta que se visualice el tamaño actualmente ajustado.
 ➤ *El ajuste del tamaño actual también se mostrará en el indicador de tamaño situado sobre el visualizador.*
- Para aplicar el ajuste de tamaño seleccionado a todo el texto, suelte **Code**.

Para activar o desactivar la función de anchura:

- Manteniendo presionada **Code**, pulse una vez **Width 3**, y mantenga presionada **Code** para hacer que se visualice el ancho actualmente ajustado.
- Siguiendo manteniendo presionada **Code**, continúe presionando **Width 3** hasta que se visualice el ancho actualmente ajustado.
 ➤ *Cuando seleccione **ON**, se encenderá el indicador de **Wide**.*
- Para aplicar el ajuste de ancho seleccionado a todo el texto, suelte **Code**.

FUNCIÓN DE ESTILO

Podrá seleccionar entre 9 estilos de caracteres distintos que podrá aplicar a su texto. Hay disponibles los siguientes ajustes de estilos:

NORMAL (A)

ABC

ITALIC (A + A)

ABC

BOLD (A)

ABC

I+BOLD (A + A)
[cursiva y negrilla]

ABC

OUTLINE (A)

ABC

I+OUTLINE (A + A)
[cursiva y perfilado]

ABC

SHADOW (A)

ABC

I+SHADOW (A + A)
[cursiva y sombreado]

ABC

VERTICAL (<)

◀ m o

El ajuste de estilo predeterminado es **NORMAL**. El indicador de estilo de la parte inferior del visualizador mostrará el ajuste del estilo.

☞ *Los caracteres que se imprimen utilizando los tamaños más pequeños pueden resultar difíciles de leer si se seleccionan ciertos ajustes de estilos (por ejemplo, **I+SHADOW**).*

Para cambiar el ajuste del estilo:

- 1 Manteniendo presionada **Code**, pulse una vez **5**^{Style}, y mantenga presionada **Code** para hacer que se visualice el estilo actualmente ajustado.
- 2 Siguiendo manteniendo presionada **Code**, continúe presionando **5**^{Style} hasta que se visualice el estilo actualmente ajustado.
⇒ El ajuste de estilo actual se mostrará en el indicador de estilo de la esquina inferior del visualizador.
- 3 Para aplicar el ajuste de estilo seleccionado a todo el texto, suelte **Code**.

FUNCIÓN DE SUBRAYADO

Podrá acentuar el texto subrayándolo.

El ajuste de subrayado predeterminado es **OFF**. Cuando haya ajustado la función de **subrayado** a **ON**, el indicador de **subrayado** de la parte derecha del visualizador se encenderá.

☞ *Si había elegido un marco, cuando seleccione el ajuste de subrayado **ON**, el ajuste del marco cambiará a **OFF** y el texto se subrayará.*







OFF



ON



Para cambiar el ajuste del subrayado:

- 1 Manteniendo presionada , pulse una vez , y mantenga presionada  para hacer que se visualice el subrayado actualmente ajustado.
- 2 Siguiendo manteniendo presionada , continúe presionando  hasta que se visualice el subrayado actualmente ajustado.
☞ *Cuando seleccione el ajuste **ON**, el indicador de **subrayado** se encenderá.*
- 3 Para aplicar el ajuste de subrayado seleccionado a todo el texto, suelte .

FUNCIÓN DE MARCOS

Con la función de **marcos**, podrá seleccionar diversos marcos y funciones destacadas para hacer un diseño más decorativo o una etiqueta con más énfasis.

Los ajustes de marcos siguientes están disponibles:

OFF

ABC

ROUND

ABC

DOT

ABC

DIAMOND

ABC



SLANT



ABC

El ajuste inicial de marco es **OFF**. Si se selecciona cualquier ajuste que no sea **OFF**, se encenderá el indicador de **marco**, situado a la derecha del visualizador.

☞ Si había elegido el ajuste de subrayado **ON**, cuando seleccione un ajuste de marco, el ajuste de subrayado cambiará a **OFF** cuando se enmarque el texto.

Para cambiar el ajuste del marco:

❶ Manteniendo presionada , pulse una vez ^{Frame}, y mantenga presionada  para hacer que se visualice el marco actualmente ajustado.

❷ Siguiendo manteniendo presionada , continúe presionando ^{Frame} hasta que se visualice el marco actualmente ajustado.

☞ El indicador de **marco** se enciende si se selecciona un ajuste que no sea **OFF**.

❸ Para aplicar el ajuste de marco seleccionado a todo el texto, suelte .

FUNCIÓN DE MÁRGENES DE LA CINTA

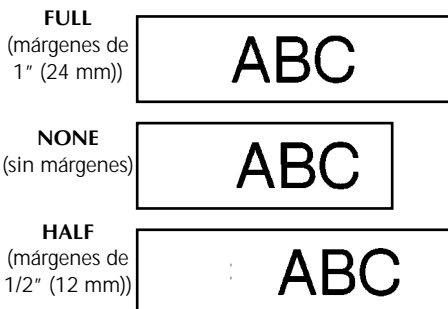

La función de **Márgenes de la cinta** le permitirá ajustar el tamaño de los márgenes izquierdo y derecho de su texto. Además, el ajuste de márgenes de la cinta **NONE** podrá utilizarse para imprimir una etiqueta con muchos estilos de formatos diferentes.

El ajuste predeterminado de márgenes de la cinta es **FULL**. Sin embargo, están disponibles también otros dos ajustes.



☞ Si ha instalado un casete de rotulación instantánea (aplicación frotando), el texto se imprimirá con el ajuste **FULL** (márgenes de 1" (24 mm)), incluso aunque seleccione otro ajuste de márgenes de cinta diferente.

Después de imprimir una etiqueta con la función **Márgenes de la cinta** ajustada

a **NONE**, mantenga pulsada  y presione  una vez para alimentar la

cinta antes de presionar la palanca del cortador de la cinta, ya que de lo contrario es posible que se corten algunos de los caracteres impresos, como se muestra a continuación.



Después de imprimir con el ajuste de márgenes de la cinta **HALF**, presione la palanca del cortador de la cinta para cortar ésta, y después utilice unas tijeras para cortar a lo largo de los puntos (:) impresos para centrar el texto dentro de la etiqueta.

Para cambiar el ajuste de la cinta:

- 1 Manteniendo presionada **Code**, pulse una vez **Margin E**, y mantenga presionada **Code** para hacer que se visualice la cinta actualmente ajustado.
- 2 Siguiendo manteniendo presionada **Code**, continúe presionando **Margin E** hasta que se visualice la cinta actualmente ajustado.
- 3 Para aplicar el ajuste de la cinta seleccionado a todo el texto, suelte **Code**.







FUNCIÓN DE LA ALINEACIÓN HORIZONTAL

Podrá elegir alinear texto en una de las tres formas disponibles. Además, si utilizó la función de **longitud** para ajustar la longitud de la etiqueta, los texto se alinearán dentro de la etiqueta de acuerdo con el ajuste de alineación horizontal seleccionado.

El ajuste inicial de la alineación horizontal es **LEFT** (izquierda), aunque también están disponibles otros dos ajustes.

LEFT	AB CDE FG	CENTER	AB CDE FG	RIGHT	AB CDE FG
-------------	-----------------	---------------	-----------------	--------------	-----------------

Para cambiar el ajuste de la alineación horizontal:

- 1 Manteniendo presionada , pulse una vez , y mantenga presionada  para hacer que se visualice la alineación horizontal actualmente ajustado.
- 2 Siguiendo manteniendo presionada , continúe presionando  hasta que se visualice la alineación horizontal actualmente ajustado.
- 3 Para aplicar el ajuste de la alineación seleccionado a todo el texto, suelte .

FUNCIÓN DE IMPRESIÓN DE ESPEJO

Con esta función, podrá imprimir el texto de modo que los caracteres puedan leerse desde el lado del adhesivo de la cinta. Si se adhieren etiquetas con impresión de espejo a un vidrio, o en otro material transparente, podrán leerse correctamente desde el lado opuesto.

⇒ Cuando emplee la función de **impresión de espejo**, el texto se imprimirá en cinta transparente.

El ajuste inicial para la impresión en modo espejo es **OFF**.







OFF



ON



Para activar o desactivar la impresión de espejo:

- 1 Manteniendo presionada , pulse una vez , y mantenga presionada  para hacer que se visualice la impresión de espejo actualmente ajustado.
- 2 Siguiendo manteniendo presionada , continúe presionando  hasta que se visualice la impresión en modo espejo actualmente ajustado.
- 3 Para aplicar el ajuste la impresión en modo espejo seleccionado a todo el texto, suelte .

FUNCIÓN DE CÓDIGO DE BARRAS

La función de **Código de barras**, que permite imprimir códigos de barras como parte de las etiquetas, es una de las características más avanzadas de la máquina.

☞ *En esta sección explicaremos cómo introducir un código de barras en su texto. No tiene el propósito de ser una introducción amplia al concepto de los códigos de barras. Para encontrar información más detallada al respecto, consulte uno de los muchos libros disponibles en el mercado.*

Como esta máquina no ha sido específicamente diseñada para hacer etiquetas de códigos de barras, es posible que algunos lectores de códigos de barras no puedan leer las etiquetas.

Imprima los códigos de barras con tinta negra sobre fondo blanco.

Cuatro parámetros distintos le permitirán crear códigos de barras personalizados.

Parámetro	Ajustes
PROTOCOL	CODE 39, CODE128, EAN128, CODABAR, UPC-E, UPC-A, EAN8, EAN13, I-2/5
WIDTH (anchura del código de barras)	LARGE, SMALL
UNDER#S (caracteres impresos debajo del código de barras)	ON, OFF
CHECK DIG. (dígito de comprobación)	OFF, ON

Los ajustes predeterminados son **CODE 39 PROTOCOL**, **LARGE WIDTH**, **UNDER#S**, ajustado a **ON**, y **CHECK DIG.** ajustado a **OFF**.

☞ *Se recomienda imprimir los códigos de barras con la función de **Margen de cinta** ajustada a **FULL** y el parámetro **WIDTH** del código de barras ajustado a **LARGE**, porque de lo contrario los códigos de barras pueden resultar difíciles de leer.*

Los códigos de barras deberán introducirse de acuerdo con las reglas siguientes:

Protocol	Número de dígitos (incluyendo los dígitos de comprobación y los códigos de inicio y parada)	Caracteres que podrán utilizarse	Notas
CODE 39	4 a 22	Números, letras, espacios, y símbolos -, \$, ., /, +, y %	El asterisco (*) no será necesario al comienzo ni al final de los códigos.
CODE128	4 a 22	Todos los caracteres ASCII	
EAN128	4 a 22	Todos los caracteres ASCII	
CODABAR	4 a 22	Números, letras, espacios, y símbolos -, \$, ., /, +, y %	Los códigos de inicio y parada deberán ser A, B, C, o D
UPC-E	6	Número	
UPC-A	13	Número	
EAN8	8	Número	
EAN13	13	Número	
I-2/5	Número par de dígitos*	Número	



* Para imprimir cada parte de los datos para un código de barras de 1-2/5 se necesitarán 2 dígitos. Por lo tanto, si se introduce un número impar de dígitos, se añadirá automáticamente "0" al comienzo de los datos cuando se imprima el código de barras. Sin embargo, "0" no aparecerá en el visualizador de cristal líquido.



Para utilizar la función de código de barras:

1 Mantenga presionado  y presione  una vez.

➤ Para cambiar los datos o parámetros de un código de barras que ya había sido creado, coloque el cursor debajo de la marca de código de barras

(||||) antes de mantener presionado  y presionar .

Un bloque solamente puede contener un código de barras. Si ya había introducido un código de barras en el bloque cuando mantenga presionado  y presionar  aparecerá el mensaje de error "1 BAR CODE / LABEL".



Para abandonar la función de **Código de barras** sin realizar ningún cambio, mantenga presionado  y presione .



- ② Escriba los datos del nuevo código de barras o edite el antiguo.

Para cambiar los ajustes de los parámetros del código de barras:

- ③ Presione .

☞ Para volver a los datos del código de barras sin cambiar ningún ajuste de parámetro, presione .



- ④ Presione  o  hasta que aparezca el parámetro que desee cambiar.

- ⑤ Presione  o  hasta que se visualice el ajuste deseado.



- ⑥ Repita los pasos ④ y ⑤ hasta haber ajustado todos los parámetros que desee.

- ⑦ Presione .

Para añadir un carácter especial a los datos del código de barras:

- ⑧ Presione  o  hasta que el cursor se coloque debajo del carácter situado a la derecha de donde desee añadir el carácter especial.

- ⑨ Presione .

- ⑩ Presione  o  hasta que se visualice el carácter especial.

☞ Cuando utilice los tipos **CODE 39** o **CODABAR** solamente podrá introducir los caracteres especiales siguientes.

Símbolo	Carácter
1	+
2	\$

Cuando utilice los tipos **EAN128** y **CODE128** solamente podrá introducir los caracteres especiales siguientes.







VALOR	CARÁCTER	VALOR	CARÁCTER	VALOR	CARÁCTER
3	#	69	ENQ	87	ETB
4	\$	70	ACK	88	CAN
11	+	71	BEL	89	EM
28	<	72	BS	90	SUB
29	=	73	HT	91	ESC
30	>	74	LF	91	{
32	@	75	VT	92	FS
59	[76	FF	92	
60	\	77	CR	93	GS
61]	78	SO	93	}
62	^	79	SI	94	RS
63	_	80	DLE	94	~
64	NUL	81	DC1	95	US
64	`	82	DC2	95	DEL
65	SOH	83	DC3	96	FNC 3
66	STX	84	DC4	97	FNC 2
67	ETX	85	NAK	100	FNC 4
68	EOT	86	SYN	102	FNC1

- 11 Presione  para añadir el carácter especial seleccionado al código de barras.

Para añadir el código de barras a su texto:

- 12 Presione .

Para borrar el código de barras de su texto:



- 1 Presione , ,  o  hasta que el cursor quede situado debajo de la mitad derecha de la marca del código de barras o a la derecha de toda la marca del código de barras.
- 2 Presione . Aparecerá el mensaje "OK TO CLEAR? ||| |||".
- 3 Presione .

TECLA PRINT Y FUNCIÓN DE AVANCE DE LA CINTA



Después de haber introducido su texto y elegido los ajustes de formato deseados, estará dispuesto para imprimir la etiqueta.

Para imprimir una etiqueta:

- Presione  una vez. Mientras la etiqueta esté imprimiéndose, se visualizará el mensaje "COPIES 1/1". La etiqueta saldrá a través de la salida de la cinta del extremo superior de la máquina.

☞ Después de haber impreso con la función **Márgenes de la cinta** ajustada a **NONE**, mantenga pulsada  y presione  una vez para hacer que avance la cinta antes de cortarla, ya que de lo contrario podrían cortarse algunos de los caracteres impresos.

Para hacer que la cinta avance:

- Mantenga pulsada  y presione . Mientras esté saliendo 1" (24 mm) de cinta, se visualizará el mensaje "FEED".















Para cortar la cinta:

- Presione la palanca del cortador de la cinta.
☞ Para evitar dañar la cinta, no intente cortarla durante la impresión ni el avance.
Si presiona con demasiada fuerza la palanca, puede romperla.

FUNCIÓN DE NUMERACIÓN

Esta función podrá utilizarse para imprimir muchas copias del mismo texto aumentando en 1 cierto número en el texto después de haber impreso cada etiqueta. Este tipo de incremento automático será muy útil para imprimir etiquetas de números en serie, etiquetas de control de producción, u otras etiquetas que requieran códigos ascendentes.











Para utilizar la función de numeración:

- 1 Presione , ,  o  para colocar el cursor debajo del número que desee aumentar.
- 2 Mantenga pulsada  y presione . En el visualizador aparecerá el mensaje "NUMBER UNTIL 1-9?".
*☞ Para abandonar la función de **numeración** sin imprimir, mantenga pulsada  y después presione  (o presione simplemente ).*
- 3 Presione una tecla numérica ( a ) correspondiente al último número que desee imprimir.
- 4 Presione  (o ) para empezar a imprimir las etiquetas. Se visualizará el número de cada copia mientras se imprime.
*☞ Después de haber impreso utilizando el ajuste de margen **NONE**, mantenga pulsada  y presione una vez  para hacer que la cinta avance antes de cortarla, ya que de lo contrario algunos caracteres no se imprimirían.*
- 5 Presione la palanca de la cuchilla de la cinta para cortar la cinta, y emplee luego unas tijeras para cortar a lo largo de los puntos impresos para separar las etiquetas.

FUNCIÓN DE IMPRESIÓN REPETIDA

Esta función le permite imprimir hasta 9 copias del mismo texto.

Para emplear la función de impresión repetida:

- 1 Mantenga presionado  y presione . Aparecerá el mensaje "COPIES UNTIL 1-9?" en el visualizador.
*☞ Para abandonar la función de **impresión repetida** sin imprimir, mantenga pulsada  y después presione  (o presione simplemente .*
- 2 Presione la tecla numérica y ( a ) correspondiente al número de etiquetas que desee.
- 3 Presione  (o ) para empezar a imprimir las etiquetas. Se visualizará el número de cada copia mientras se imprime.
*☞ Después de haber impreso utilizando el ajuste de margen **NONE**, mantenga pulsada  y presione una vez  para hacer que la cinta avance antes de cortarla, ya que de lo contrario algunos caracteres no se imprimirían.*
- 4 Presione la palanca de la cuchilla de la cinta para cortar la cinta, y emplee luego unas tijeras para cortar a lo largo de los puntos impresos para separar las etiquetas.

FUNCIONES DE LA MEMORIA

Usted podrá utilizar la memoria para almacenar sus archivos de texto más frecuentemente utilizados. El texto permanecerá en la memoria, incluso después de haberlo eliminado del visualizador utilizando la función de **reposición** (see página 17).



Cuando almacena cada archivo, a éste se le asignará un número para poder invocarlo fácilmente. En la memoria podrá almacenar hasta 9 archivos de texto, o aproximadamente 300 caracteres. Cada archivo de texto almacenado podrá tener un máximo de 99 caracteres.

Como, cuando se invoque un archivo de texto con la función de **invocación**, se invocará una copia del archivo almacenado, el texto podrá editar o imprimirse sin cambiar el archivo originalmente almacenado. Cuando ya no necesite un archivo o cuando ya no lo necesite, podrá utilizar la función de **borrado de la memoria**.

☞ *Cuando tenga que insertar nuevas pilas, hágalo antes de cinco minutos de haber extraído las viejas, ya que de lo contrario los archivos de texto almacenados en la memoria se perderían (a menos que la máquina esté enchufada en un tomacorriente de la red con el adaptador de alimentación de CA).*

ALMACENAMIENTO DE TEXTO

Para almacenar un archivo de texto:



1 Mantenga pulsada  y presione .



2 Presione  o  hasta que pardee **STORE**.

3 Presione . En el visualizador aparecerá el mensaje "STORE SELECT 1-9?".

☞ *Si ya están almacenados 300 caracteres, en el visualizador aparecerá el mensaje de error "MEMORY FULL!". Cuando ocurra esto, tendrá que borrar un mensaje existente antes de poder almacenar otro nuevo.*



*Para abandonar la función de **almacenamiento** del texto, mantenga pulsada*

sada  y presione  (o simplemente presione .

4 Presione la tecla ( ) correspondiente al número de archivo en el que desee almacenar texto. El texto se almacenará en el número de archivo seleccionado y el texto previamente mostrado en el visualizador desaparecerá.















☞ *Si ya hay un archivo almacenado con el número de archivo seleccionado, en el visualizador aparecerá el mensaje "OVERWRITE?", y usted tendrá que decidir entre reescribir o borrar tal archivo.*

Par reescribir un archivo almacenado con otro nuevo:

- Presione  para borrar el archivo previamente almacenado y almacenar el nuevo con el número seleccionado.
☞ Para retroceder y elegir otro número de archivo sin reescribir el archivo de texto, presione , y después presione una tecla numérica correspondiente a un número de archivo diferente.



INVOCACIÓN DE TEXTO



Para invocar un archivo de texto:

- 1 Mantenga pulsada  y presione .
- 2 Presione  o  hasta que paratee **RECALL**.
- 3 Presione . En el visualizador aparecerá el mensaje "RECALL SELECT 1-9?".
☞ Para abandonar la función de **invocación** sin invocar texto, mantenga pulsada  y presione  (o presione simplemente ).
- 4 Presione la tecla ( a ) correspondiente al número de archivo que desee invocar. Aparecerá el texto almacenado con el número de archivo seleccionado.
☞ Para ver otras partes del archivo de texto seleccionado, presione  o .
Para hacer que se visualice el texto almacenado en otros números de archivos, presione  o , o la tecla correspondiente a otro número de archivo.
- 5 Presione . Cualquier texto previamente introducido en el visualizador se borrará y el texto introducido en el número de archivo seleccionado se invocará en el visualizador.



BORRADO DE UN ARCHIVO



Para borrar un archivo de texto:



1 Mantenga pulsada  y presione .



2 Presione  o  hasta que pardee **CLEAR**.

3 Presione . En el visualizador aparecerá el mensaje "CLEAR SELECT 1-9?".

☞ Para abandonar la función **borra de la memoria** sin borrar el archivo de texto, mantenga pulsada  y presione  (o presione simplemente ).



4 Presione la tecla ( a ) correspondiente al número de archivo que desee borrar. En el visualizador aparecerá el texto almacenado con el número de archivo seleccionado.

☞ Para ver otras partes del archivo de texto seleccionado, presione  o .









Para hacer que se visualice el texto almacenado en otros números de archivos, presione  o , o la tecla correspondiente a otro número de archivo.









5 Para borrar el archivo de texto seleccionado, presione .

SOLUCIÓN DE PROBLEMAS

Problema	Remedio
1. El visualizador se queda en blanco después de haber conectado la alimentación de la máquina.	<ul style="list-style-type: none"> • Compruebe que el adaptador de CA (AD-60) esté correctamente enchufado. • Si está empleando pilas alcalinas, compruebe que estén correctamente insertadas. • Si las pilas están gastadas, reemplácelas por otro nuevo.
2. La máquina no imprime o los caracteres impresos quedan borrosos.	<ul style="list-style-type: none"> • Compruebe si está utilizando el adaptador de CA correcto (AD-60), y si está adecuadamente conectado. • Compruebe si ha insertado correctamente el casete de cinta. • Si el casete de cinta está vacío, reemplácelo por otro nuevo. • Cerciórese de que la cubierta posterior esté fijada.
3. Los archivos de texto almacenados en la memoria ya no están ella.	<ul style="list-style-type: none"> • Si las pilas están gastadas, reemplácelas por otro nuevo.
4. Los caracteres impresos no se forman correctamente.	<ul style="list-style-type: none"> • Si está empleando pilas alcalinas, quizás estén gastadas. Pruebe utilizando el adaptador de CA o reemplace las pilas por otras nuevas. • Compruebe si está utilizando el adaptador de CA correcto (AD-60), y si está adecuadamente conectado.
5. Aparece una línea horizontal en blanco a través de la etiqueta impresa.	<ul style="list-style-type: none"> • Limpie el cabezal de impresión como se ha explicado en la página 7 y 8.
6. Aparecen franjas.	<ul style="list-style-type: none"> • Se ha terminado la cinta. Reemplace el casete de cinta por otro nuevo.
7. La máquina se ha "bloqueado" (es decir, no responde cuando se presiona una tecla).	<ul style="list-style-type: none"> • Desconecte la alimentación de la máquina, y entonces, mientras mantiene presionado  y , vuelva a conectar la alimentación. El texto y los formatos del visualizador y todos los archivos de texto almacenados en la memoria quedan borrados.

LISTA DE MENSAJES DE ERROR

Mensaje de error	Causa	Remedio
1 BAR CODE / LABEL	<ul style="list-style-type: none"> Este mensaje aparecerá si ya se había un código de barras al bloque cuando mantenga presionado  y presione  <small>Barcode</small>. 	<ul style="list-style-type: none"> Limite el número de códigos de barras de un bloque a uno.
4 DIGIT MIN.!	<ul style="list-style-type: none"> Este mensaje aparecerá cuando como datos de código de barras haya introducido menos del mínimo de cuatro dígitos. 	<ul style="list-style-type: none"> Introduzca el mínimo de cuatro dígitos antes de presionar  <small>Memory</small>.
4 LINE LIMIT!	<ul style="list-style-type: none"> Este mensaje aparecerá si ya existen cuatro líneas cuando presione  <small>Memory</small>. 	<ul style="list-style-type: none"> Limite el número de líneas de un bloque a cuatro.
BATTERIES WEAK!	<ul style="list-style-type: none"> Este mensaje aparece cuando las pilas alcalinas instaladas están gastadas. 	<ul style="list-style-type: none"> Reemplace las pilas o emplee el adaptador de CA.
BUFFER EMPTY!	<ul style="list-style-type: none"> Este mensaje aparecerá si mantiene pulsada  y presiona ,  <small>Number</small>, o  <small>Repeat</small>, pero no hay texto introducido en el visualizador. Este mensaje aparecerá si trata de imprimir, pero no ha introducido texto. Este mensaje aparecerá si intenta almacenar un archivo de texto, pero no hay texto introducido en el visualizador. 	<ul style="list-style-type: none"> Introduzca texto antes de iniciar la función. Introduzca texto antes de imprimir. Introduzca texto antes de almacenar.

Mensaje de error	Causa	Remedio
BUFFER FULL!	<ul style="list-style-type: none"> Este mensaje aparecerá si intenta introducir un carácter, símbolo, código de barras, retorno, o espacio después de haber introducido ya 99 caracteres. 	<ul style="list-style-type: none"> Borre cierto texto existente a fin de poder introducir más.
CAN'T HERE!	<ul style="list-style-type: none"> Este mensaje aparecerá si intenta introducir un carácter, símbolo, código de barras, retorno, o espacio mientras el cursor esté situado debajo de la mitad derecha de una marca de código de barras. Este mensaje aparecerá si el cursor se encuentra al final del texto cuando mantenga pulsada  y presione . 	<ul style="list-style-type: none"> Mueva el cursor o borre el código de barras antes de introducir el carácter, el símbolo, o el retorno. Mueva el cursor hasta debajo de un número antes de mantener pulsada  y presionar .
CHANGE ADAPTOR!	<ul style="list-style-type: none"> Este mensaje aparece si se está empleando un adaptador de alta tensión. 	<ul style="list-style-type: none"> Desconecte el adaptador de alta tensión y conecte el adaptador diseñado exclusivamente para esta máquina.
INPUT WHOLE CODE!	<ul style="list-style-type: none"> Este mensaje aparecerá si el número ajustado de dígitos no se ha introducido en los datos del código de barras. 	<ul style="list-style-type: none"> Introduzca el número correcto de dígitos.
INVAL. CHARS!	<ul style="list-style-type: none"> Este mensaje aparecerá si el cursor se encuentra debajo de un carácter que no sea un número o una marca de retorno (↵) cuando mantenga pulsada  y presione . 	<ul style="list-style-type: none"> Mueva el cursor hasta debajo de un número antes de mantener pulsada  y presionar .

Mensaje de error	Causa	Remedio
LENGTH LIMIT!	<ul style="list-style-type: none"> Este mensaje aparecerá si utilizó la función de longitud para ajustar una longitud inferior a 1,6" (4,0 cm) o más de 11,8" (30,0 cm). 	<ul style="list-style-type: none"> Ajuste la longitud de la etiqueta entre 1,6" (4,0 cm) y 11,8" (30,0 cm).
LINE LIMIT!	<ul style="list-style-type: none"> Este mensaje aparece si el número de líneas del texto es mayor que el número máximo de líneas posible para la cinta instalada. 	<ul style="list-style-type: none"> Reduzca el número de líneas o instale una cinta más ancha.
MEMORY FULL!	<ul style="list-style-type: none"> Este mensaje aparecerá si intenta almacenar un archivo de texto después de haber almacenado ya 300 caracteres en la memoria. 	<ul style="list-style-type: none"> Borre un archivo que no desee para dejar espacio para el nuevo.
NEED A, B, C, D START&END	<ul style="list-style-type: none"> Este mensaje aparecerá si no ha introducido una letra de A a D al comienzo y al final de los datos de códigos de barras cuando esté utilizando el protocolo CODBAR. 	<ul style="list-style-type: none"> Introduzca una letra de A a D al comienzo y al final de los datos de código de barras.
NO FILES!	<ul style="list-style-type: none"> Este mensaje aparece si intenta llamar o borrar un archivo de texto de la memoria cuando realmente no hay ninguno almacenado. 	<ul style="list-style-type: none"> Almacene primero un archivo de texto.
NO TAPE!	<ul style="list-style-type: none"> Este mensaje aparecerá si intenta imprimir una etiqueta o hacer que avance la cinta cuando no haya casete de cinta instalado. 	<ul style="list-style-type: none"> Instale un casete de cinta e inténtelo de nuevo.

Mensaje de error	Causa	Remedio
NUMBER TOO SMALL!	<ul style="list-style-type: none"> Este mensaje aparecerá si el último número ajustado para imprimirse es inferior al seleccionado en el texto cuando utilice la función Numeración. 	<ul style="list-style-type: none"> Presione la tecla de un número que sea superior al del número del texto.
REPLACE BATTERIES!	<ul style="list-style-type: none"> Este mensaje aparece cuando las pilas alcalinas instaladas están casi gastadas. 	<ul style="list-style-type: none"> Reemplace las pilas o emplee el adaptador de CA.
ROM PROBLEM!	<ul style="list-style-type: none"> Este mensaje aparece si hay algún problema con la memoria de acceso aleatorio de la máquina. 	<ul style="list-style-type: none"> Póngase en contacto con su representante de servicio.
SYSTEM ERROR!	<ul style="list-style-type: none"> Este mensaje aparece si hay algún problema con el software de la máquina. 	<ul style="list-style-type: none"> Póngase en contacto con su representante de servicio.
TEXT TOO HIGH!	<ul style="list-style-type: none"> Este mensaje aparece si el tamaño del texto es más grande que el ancho de la cinta instalada. 	<ul style="list-style-type: none"> Reduzca el tamaño de los caracteres o instale una cinta más ancha.
TEXT TOO LONG!	<ul style="list-style-type: none"> Este mensaje aparece si la longitud del texto es mayor que la longitud que se ha ajustado para la etiqueta utilizando la función de longitud. 	<ul style="list-style-type: none"> Borre algo de texto, reduzca el ancho de los caracteres o incremente la longitud ajustada de la etiqueta.

ESPECIFICACIONES

HARDWARE

Dispositivo de entrada:	Teclado con 52 teclas (incluyendo la tecla de alimentación)
LCD:	12 caracteres × 2 líneas (7 × 5 puntos/carácter) 17 indicadores
Cinta de impresión:	Cinta TZ Cuatro anchos disponibles: 1/4" (6 mm) 3/8" (9 mm) 1/2" (12 mm) 3/4" (18 mm)
Alimentación:	Seis pilas alcalinas AA (AM3, LR6) o adaptador de CA opcional (AD-60) Desconexión automática de la alimentación si no se pulsa ninguna tecla durante 5 minutos
Cabezal de impresión:	128 puntos / 180 dpi
Dimensiones:	4 3/4" (121 mm)(W) × 7 31/64" (190 mm)(D) × 2 51/64" (71 mm)(H)
Peso:	1,1 lbs. (520 g) (sin casete de cinta ni pilas instalados)

SOFTWARE

Tamaño de la memoria intermedia:	Máximo de 99 caracteres Máximo de cuatro líneas
Tamaño de la memoria:	300 caracteres
Tamaño de caracteres:	Cinco tamaños (9, 12, 18, 24 y 36 puntos) + AUTO Todos disponibles en el modo normal y ancho (wide)
Estilos de impresión:	Normal, negrilla, perfilado, sombreado (todos pueden combinarse con cursiva), y Vertical

ACCESORIOS

● Accesorios de consumo

Adquiera los casetes de cinta en el distribuidor autorizado que le quede más cerca. Emplee sólo cintas Brother TZ con esta máquina. **Brother no puede hacerse responsable por los problemas causados por el empleo de accesorios de consumo no autorizados.** No emplee cintas que no tengan la marca .

N.º de producto	Descripción	CANT./PAQUETE	PRECIO
Cintas laminadas de 3/4" (18 mm)			
TZ-141	Caracteres negros sobre fondo transparente	1	\$20.99
TZ-145	Caracteres blancos sobre fondo transparente	1	\$20.99
TZ-241	Caracteres negros sobre fondo blanco	1	\$20.99
TZ-242	Caracteres rojos sobre fondo blanco	1	\$20.99
TZ-243	Caracteres azules sobre fondo blanco	1	\$20.99
TZ-344	Caracteres dorados sobre fondo negro	1	\$24.99
TZ-345	Caracteres blancos sobre fondo negro	1	\$23.99
TZ-441	Caracteres negros sobre fondo rojo	1	\$20.99
TZ-541	Caracteres negros sobre fondo azul	1	\$20.99
TZ-545	Caracteres blancos sobre fondo azul	1	\$23.99
TZ-641	Caracteres negros sobre fondo amarillo	1	\$20.99
TZ-741	Caracteres negros sobre fondo verde	1	\$20.99
TZ-B41	Caracteres negros sobre fondo naranja fluorescente	1	\$24.99
TZ-M41	Caracteres negros sobre fondo claro (MATE)	1	\$20.99
TZ-S241	Caracteres negros industriales (adhesivo fuerte) sobre adhesivo blanco	1	\$21.99
TZ-WB41	Caracteres negros sobre fondo Bugs Bunny	1	\$23.99
TZ-WT41	Caracteres negros sobre fondo Taz	1	\$23.99
TZ-WS41	Caracteres negros sobre fondo Tweety & Sylvester	1	\$23.99
Cintas laminadas de 1/2" (12 mm)			
TZ-131	Caracteres negros sobre fondo transparente	1	\$16.99
TZ-231	Caracteres negros sobre fondo blanco	1	\$17.99
TZ-232	Caracteres rojos sobre fondo blanco	1	\$17.99
TZ-335	Caracteres blancos sobre fondo negro	1	\$20.99
TZ-S231	Caracteres negros industriales (adhesivo fuerte) sobre adhesivo blanco	1	\$18.99

N.º de producto	Descripción	CANT./PAQUETE	PRECIO
Cintas laminadas de 3/8" (9 mm)			
TZ-121	Caracteres negros sobre fondo transparente	1	\$14.99
TZ-221	Caracteres negros sobre fondo blanco	1	\$16.99
TZ-325	Caracteres blancos sobre fondo negro	1	\$18.99
TZ-421	Caracteres negros sobre fondo rojo	1	\$16.99
TZ-S221	Caracteres negros industriales (adhesivo fuerte) sobre adhesivo blanco	1	\$17.99
Cintas laminadas de 1/4" (6 mm)			
TZ-111	Caracteres negros sobre fondo transparente	1	\$12.99
TZ-211	Caracteres negros sobre fondo blanco	1	\$14.99
TZ-315	Caracteres blancos sobre fondo negro	1	\$17.99
TZ-S211	Caracteres negros industriales (adhesivo fuerte) sobre adhesivo blanco	1	\$15.99

Cintas especiales

N.º de producto	Descripción	CANT./PAQUETE	PRECIO
TZ-SE4	Caracteres negros sobre cinta de seguridad de 3/4" (18 mm)	1	\$29.99
TZ-FA3	Caracteres azules sobre cinta de tela de 1/2" (12 mm)	1	\$24.99

Juego de membretes

N.º de producto	Descripción	CANT./PAQUETE	PRECIO
SK-MB	Juego para hacer sellos para sello con tinta negra medio	1	\$37.99
SH-MB	Estampador adicional para sello con tinta negra medio	1	\$24.99

Opciones

N.º de producto	Descripción	CANT./PAQUETE	PRECIO
TZ-CL4	Casete limpiador del cabezal de impresión	1	\$20.99
AD-60	Adaptador de CA	1	\$24.99

