

Thank you for purchasing a Brother P-touch Home label maker! With your new P-touch Home label maker, you can create labels to organize and personalize items just the way you want them around your home. Select from the many frames, character sizes and styles to design beautiful custom labels. In addition, the variety of tape cartridges available allows you to print labels with different widths and exciting colors.

For a complete list of tapes compatible with your label maker, visit us at: [www.brother.com](http://www.brother.com)

Please read this guide, including all Precautions, before using this label maker. After reading this guide, keep it in a safe place.

D01EL0001



## Safety Precautions

**WARNING** Indicates a potentially hazardous situation which, if not avoided, could result in death or serious injuries.

- Follow these guidelines to avoid the risk of fire, burns, injury, electric shocks, rupture, overheating, abnormal odors or smoke.**
- Always use the specified voltage and the suggested AC Adapter (AD-24) for the label maker to prevent any damage or failure.
  - Do not overload the power cord.
  - Do not place heavy objects on, or damage the power cord or plug. Do not forcibly bend or pull the power cord. Always hold the AC Adapter when disconnecting from the power outlet.
  - Make sure that the plug is fully inserted to the power outlet. Do not use an outlet that is loose.
  - Do not allow the label maker, AC Adapter, power plug, or batteries to get wet, for example, by handling them with wet hands or spilling beverages on to them.
  - Since loss of eyesight may result when leaked fluid from batteries gets into your eyes, immediately rinse your eyes with a large amount of clean water, and then seek medical attention.
  - Do not disassemble or modify the label maker, AC Adapter, or batteries.
  - Do not allow a metal object to contact both the plus and minus ends of a battery.
  - Do not use sharp objects, such as tweezers or a metallic pen, to change the batteries.
  - Do not throw the batteries into fire or expose to heat.
  - Disconnect the AC Adapter and remove batteries immediately and stop using the label maker if you notice abnormal odor, heat, discoloration, deformation or anything unusual while using or storing it.
  - Do not use a damaged or leaking battery as the fluid may get on your hands.
  - Do not use a deformed or leaking battery or one whose label is damaged. There is a possibility of generating heat.

## CAUTION

Indicates a potentially hazardous situation which, if not avoided, may result in minor or moderate injuries.

- Follow these guidelines to avoid personal injury, liquid leakage, burns or heat.**
- When the label maker is not being used, store it out of the reach of children. In addition, do not allow children to put the label maker parts or labels in their mouths. If any object has been swallowed, seek medical attention.
  - Do not touch metal parts around the Print Head immediately after printing.
  - Do not touch the Cutter Blade.
  - If leaked fluid from batteries gets on your skin or clothes, immediately rinse them with clean water.
  - Remove the batteries and disconnect the AC Adapter if you do not intend to use the label maker.
  - Do not use a battery other than that specified. Do not use combinations of old and new batteries or combinations of different types, different charging levels, different manufacturers or different models. Do not insert a battery with its plus and minus ends reversed.
  - Do not drop or hit the label maker or AC Adapter.
  - Do not press on the LCD display.
  - Do not put your finger inside the label maker when you close the Cassette Cover.
  - Before using Ni-MH rechargeable batteries, carefully read the instructions for the batteries and battery charger, and be sure to use them correctly.
  - When using Ni-MH rechargeable batteries, charge the batteries with a specialized battery charger before using the batteries.

## General Precautions

- Depending on the location, material, and environmental conditions, the label may unpeel or become irremovable, the color of the label may change or be transferred to other objects. Before applying the label, check the environmental conditions and the material.
  - Do not use the label maker in any way or for any purpose not described in this guide. Doing so may result in accidents or damage the label maker.
  - Use only genuine Brother TZe tapes with the label maker. Do not use tapes that do not have the mark.
  - Only use a soft, dry cloth to clean the label maker; never use alcohol or other organic solvents.
  - Increase the separation between the equipment and receiver.
  - Connect the equipment into an outlet on a circuit different from that to which the receiver is connected.
  - Consult the dealer or an experienced radio/TV technician for help.
- Important:** Changes or modifications not expressly approved by Brother Industries, Ltd. could void the user's authority to operate the equipment.

temperatures (example on the dashboard or in the back of your car) or high humidity, or in dusty locations.

- Do not apply excessive pressure to the Tape Cutter Lever.
- Do not try to print if the Tape Cassette is empty; it will damage the Print Head.
- Do not pull the tape while printing or feeding; it will damage the tape and the label maker.
- Any data stored in memory will be lost due to failure or repair of the label maker, or if the battery expires.
- The label maker is not equipped with a charging feature for rechargeable batteries.
- The printed text may differ from the text that appears in the LCD.
- The length of the printed label may differ from the displayed label length.
- A protective clear plastic sticker is placed over the display during manufacturing and shipping. This sticker should be removed prior to use.
- When power is disconnected for more than three minutes, all text, format settings and any text files stored in the memory will be cleared.

**Federal Communications Commission (FCC) Supplier's Declaration of Conformity (USA)**

Responsible Party: Brother International Corporation  
200 Crossing Boulevard  
Bridgewater, NJ 08807-0911, U.S.A.  
TEL: (908) 704-1700

Label Maker: PT-D202

This equipment complies with Part 15 of the FCC Rules. Operation is subject to the following two conditions: (1) This equipment may not cause harmful interference, and (2) this equipment must accept any interference received, including interference that may cause undesired operation.

This equipment complies with Part 15 of the FCC Rules. These limits are designed to provide reasonable protection against harmful interference to residential installations. This equipment generates, uses and can radiate radio frequency energy and, if not installed and used in accordance with the instructions, may cause harmful interference to radio communications. However, there is no guarantee that interference will not occur in a particular installation. If this equipment does cause harmful interference to radio or television reception, which can be determined by turning the equipment off and on, the user is encouraged to try to correct the interference by one or more of the following measures:

- Reorient or relocate the receiving antenna.
- Increase the separation between the equipment and receiver.
- Connect the equipment into an outlet on a circuit different from that to which the receiver is connected.
- Consult the dealer or an experienced radio/TV technician for help.

**Important:** Changes or modifications not expressly approved by Brother Industries, Ltd. could void the user's authority to operate the equipment.

## BASIC USAGE

### Entering Text

You can enter a maximum of 80 characters and spaces for a text label, and 50 characters and spaces if using templates.

To cancel any operation, press **Esc**.

### Switching Upper Case/Lower Case

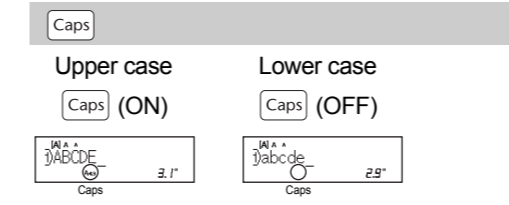

### Creating Two-Line Tapes

Move the cursor to where you want to start the next line and press **Enter**. Use either 0.35" (9 mm) or 0.47" (12 mm) tape for two-line printing.

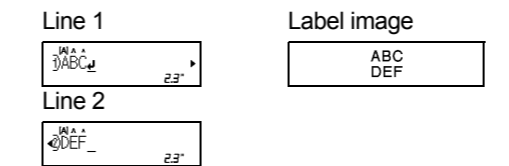

### NOTE

- The return symbol ( $\mu$ ) appears when you press the **Enter** key.

### Entering Tabs

- You can also set a tab by pressing **Tab**.
- The tab symbol appears when you insert a tab in the text.

### Changing Tab Length

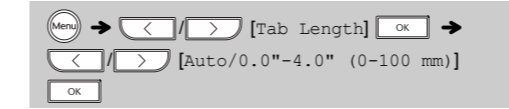

### NOTE

- If you prefer to use the optional AC Adapter (AD-24; not included) instead of using batteries:

  - Insert the Power Adapter cord into the AC Adapter Jack on the side of the label maker.
  - Insert the Power Adapter into an AC electrical outlet.

*For backup memory, we recommend using both batteries AND the optional AC Adapter, in the event that one or the other power method fails.*

## Printing Labels (cont)

### Setting Margins

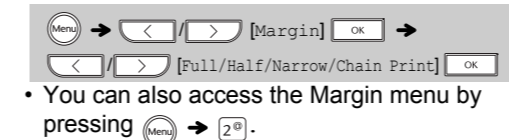

- You can also access the Margin menu by pressing **2**.

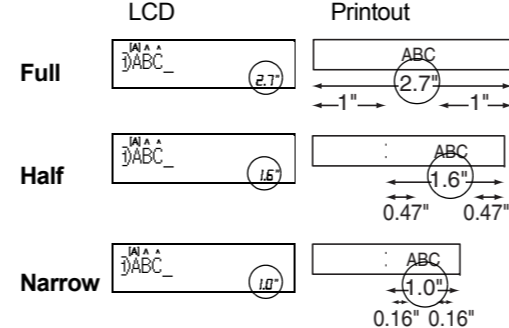

### NOTE

To print more than 1 copy of a label with minimum margin, set the margin to **Narrow**.

**[Chain Print]** (tape-saving option)  
Use this option to print multiple different labels with narrow margins. This option saves tape.

- Enter your text.
- Press **Print**. [Copies:] appears on the LCD.
- Press the number keys to enter the number of copies you want of this text.
- Press **OK** to start printing.
- When [OK to Feed?] appears on the LCD, press **Esc** to change the text.
- Clear the text, enter the text you want on the next label, and then press **Print**.
- After your last label prints, when [OK to Feed?] appears on the LCD, press **OK**.

### NOTE

- When you use **[Chain Print]**, feed the tape before pressing the Tape Cutter Lever (**Shift** + **Print**), otherwise part of the text may be cut off.
- Do not pull the tape, as this may damage the Tape Cassette.

### Entering Accented Characters



- Refer to the **Accented Characters** table in this guide.
- The order of accented characters varies based on the language you selected.

### Changing Label Length

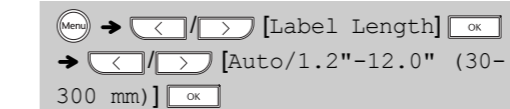

### NOTE

- After printing a label, cut along the printed dots (·) with scissors so the label length matches what is shown on the LCD.
- The lock symbol appears when you set a specific label length.
- To return to the default length (automatic, based on text length), press **Space**, and [Auto] appears on the LCD.

### Clearing Text and Settings

To delete individual letters and spaces, press **Del**.

To delete all text:

To delete all text and settings:

### Cursor Keys

To move to the end of your text:

To move to the beginning of your text:

## Printing Labels

### Preview

- Pressing the **Preview** key displays a preview of the label, and may differ from the actual label when printed.
- If the LCD cannot display all the text at once, press **Left/Right** to display the hidden text.
- Press **OK**, **Print**, or **Esc** to exit Preview mode.

### Feeding (Tape Feed)



- This function feeds approximately 1" (25 mm) of blank tape.
- Do not pull the tape, as this may damage the Tape Cassette.

### Printing



- If you need only one copy of the label, press **OK** after you press **Print**.
- You can print up to nine copies of each label.
- Press a number key to specify the number of copies you wish to print.
- DO NOT touch the Tape Cutter Lever while the message [Printing...] or [Feeding...] appears on the LCD.
- When printing stops, push the Tape Cutter Lever.
- To remove label backing, fold the label lengthwise (with the text facing inward), to expose the inside edges that run down the center of the tape backing. Peel and apply.

### Using Print Options

**[Numbering]**  
You can print a series of up to nine labels using auto-numbering. Use this feature to automatically increase a selected number by 1 after each one is printed.

**Ex:** Print copies of a label containing a serial number (0123, 0124, and 0125)

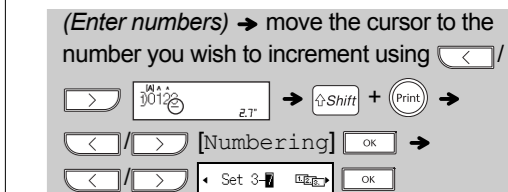

- Select the highest number you wish to print when setting the number.

**[Mirror]**  
**Ex:** To Mirror Print "J.SMITH", follow the instructions below after entering "J.SMITH".



**[Enter text or characters]**

**Print?** **OK**

- Use clear tape when using this function, so the labels can be read correctly from the opposite side when attached on glass, windows, or other transparent surfaces.

## GETTING STARTED

### Installing Power Supply and Tape Cassette

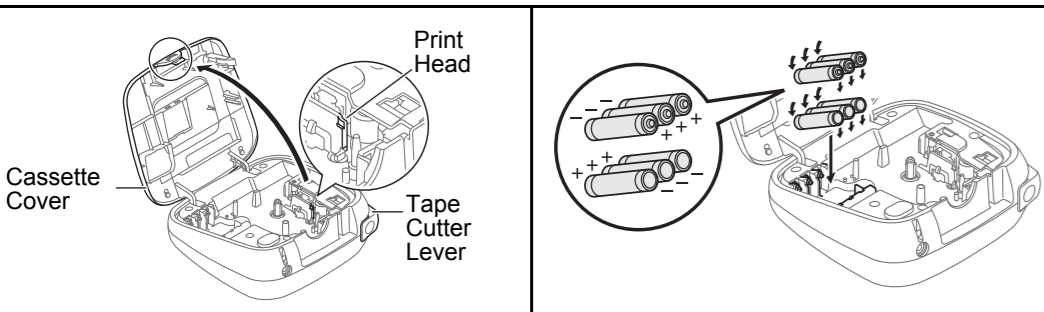

With the LCD facing down, open the Cassette Cover by pressing the grooved tab and pushing in the direction of the arrow, as illustrated.

If a Tape Cassette is already installed, remove it by pulling it straight up.

When replacing batteries or Tape Cassettes, make sure the power is turned off.

This label maker requires six (6) AAA alkaline batteries or six (6) fully charged Ni-MH batteries, not included.

Insert the Tape Cassette following the drawing marked inside the case. Gently press the Tape Cassette into the label maker until it locks into place.

- Make sure your Tape Cassette is marked .
- Use only tape widths of 0.13" (3.5 mm), 0.23" (6 mm), 0.35" (9 mm), or 0.47" (12 mm).
- If your TZe is packaged with protective plastic, be sure to remove the plastic before inserting the Tape Cassette.
- Use only Brother TZe tapes with this machine.
- Make sure that the End of the Tape feeds under the Tape Guide.

Close the Cassette Cover and gently press until it locks into place.

### NOTE

- If you prefer to use the optional AC Adapter (AD-24; not included) instead of using batteries:

  - Insert the Power Adapter cord into the AC Adapter Jack on the side of the label maker.
  - Insert the Power Adapter into an AC electrical outlet.

*For backup memory, we recommend using both batteries AND the optional AC Adapter, in the event that one or the other power method fails.*

## LCD and Keyboard

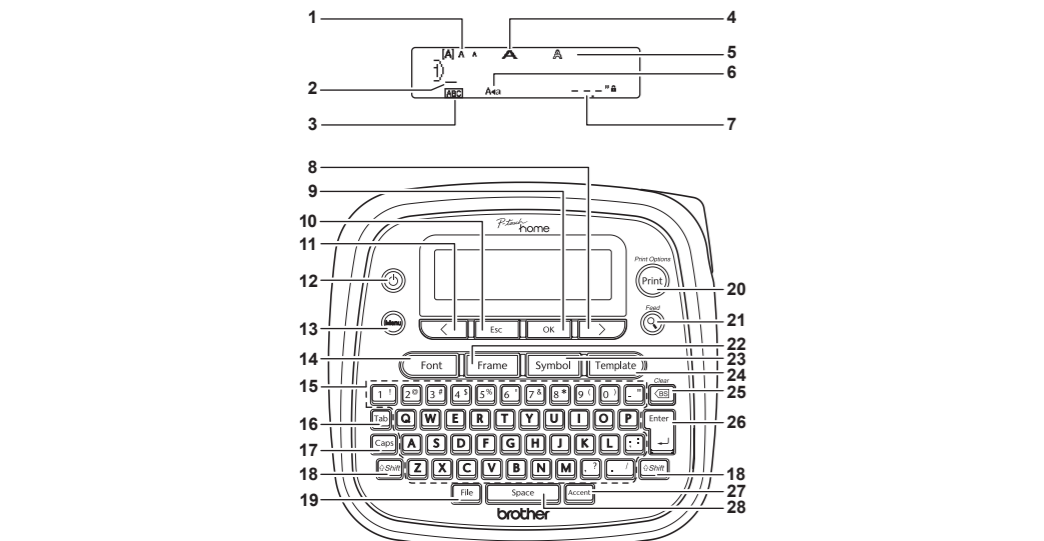

- Font Size
- Cursor
- Underline/Frame
- Width
- Style
- Caps
- Label Length
- Cursor key : Right (Use with Shift key to go to end of the text.)
- OK key
- Escape key
- Cursor key : Left (Use with Shift key to go to top of the text.)
- Power key
- Menu key
- Font key
- Character key
- Tab key
- Caps key
- Shift key
- File key
- Print key
- Preview key
- Frame key
- Symbol key
- Template key
- Backspace key
- Enter key
- Accent key
- Space key

- Pressing the **Preview** key (21) displays a preview of the label, and may differ from the actual label when printed.
- Label length shown on the LCD may differ slightly from the actual length when printed.

## Specifications

**Dimensions:** (W x D x H) Approx. 6.49" x 6.10" x 2.67" (Approx. 165 (W) x 155 (D) x 68 (H) mm)

**Weight:** Approx. 1.08 lb. (Approx. 490 g) (without batteries and Tape Cassette)

**Power supply:** Six AAA alkaline batteries (LR03) Six AAA Ni-MH batteries (HR03)\*1 Optional AC Adapter (AD-24)

**Tape Cassette:** Brother TZe tape (width) 0.13" (3.5 mm), 0.23" (6 mm), 0.35" (9 mm), 0.47" (12 mm)

\*1 Visit us at [support.brother.com](http://support.brother.com) for the latest information about the recommended batteries.

For FAQs, Troubleshooting, and manuals, visit: [support.brother.com](http://support.brother.com).

## Initial Settings

- Turn your label maker on. Supply power by using six AAA batteries or the optional AC Adapter (AD-24), and then press **Power**.

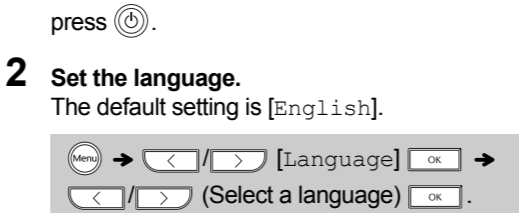

- Set the language. The default setting is [English].



### NOTE

- The label maker automatically turns off if no keys are pressed within five minutes.
- To cancel any operation, press **Esc**.
- After pressing **OK**, [Accepted] appears for approximately one second.

- Install a new Cutter Unit. Push it in gently until it locks into place.

## Accessories

Visit [www.brother-usa.com](http://www.brother-usa.com) for a list of available Brother P-touch tapes

**AC Adapter:** AD-24

**Cutter Unit:** TC-4 (replacement)

Over time, the Cutter Blade may become blunt from repetitive use. If the Cutter does not cut tape cleanly, replace the Cutter Unit. Contact your local authorized Brother reseller and order item TC-4, the Cutter Unit.

### Replacing the Cutter Unit

- Remove the two sections of the Cutter Unit (green) in the direction of the arrows as illustrated below.

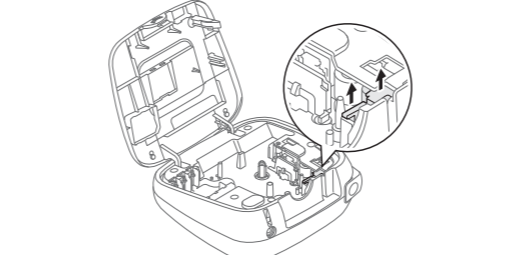

### WARNING

Do not touch the cutter blade directly with your fingers.

## USING TEMPLATES

### Home Label

Use Home Label templates to create polished labels by selecting one of our predesigned formats. Refer to the **Home Label Templates** table in this guide.

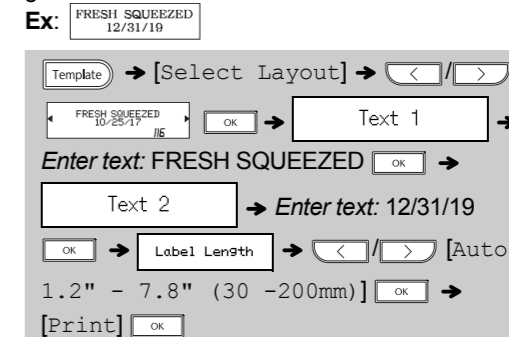

### NOTE

- Depending on the format you have selected, the entire contents of your text may not be printed. For example, if you selected a fixed Label Length and the text is too long, an error message [Text Limit!] will appear.
- Templates cannot be edited.
- Only the highlighted symbols, shaded in the **Basic Symbols/Pictograph Symbols** table in this guide, can be used in Deco Mode.
- To clear all text, press **Shift** + **Del**. When [Clear?] appears, press **OK** to clear. Press **Esc** to cancel.
- When you access templates, your most recent label created with a template opens automatically.
- Press **Esc** to return to the previous step.

### Deco Mode

Use Deco Mode templates to add visual texture to your labels. Refer to the **Deco Mode Formats** table in this guide.

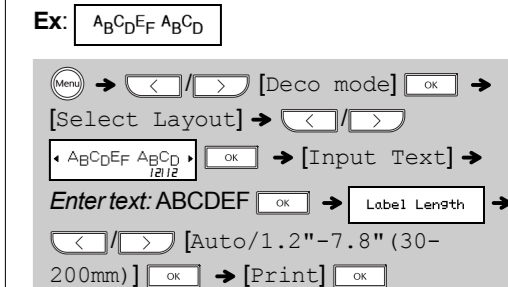

- To exit a template and return to the text entry screen, do one of following:
  - Press **Esc**.
  - Press **Left/Right** to select [Cancel], and then press **OK** when "Print" appears on the LCD.
- Templates can be used ONLY with 0.47" (12 mm) Tape Cassettes.
- Maximum label length is 7.8" (200 mm) when using templates.
- When you select [Auto] for [Label Length], the label length is automatically adjusted. The text prints once.
- Press **Space** to return to the [Auto] setting for [Label Length].



